

Climate Conscious Architecture and Urban Design in Jordan

Towards energy efficient buildings and
improved urban microclimate

Keywords

Climatic design	Passive cooling
Climate zoning	Passive heating
Computer tools	Thermal comfort
Energy conservation	Thermal insulation
Energy use	Thermal performance
Indoor climate	Urban climate
Jordan	Urban design
Laboratory tests	Urban regulations
Microclimate	Ventilation

Climate Conscious Architecture and Urban Design in Jordan
© 2009, Housing Development & Management and the Royal Scientific Society and the authors

Layout: Jan-Anders Mattsson
Language editing: Yatwan Hui
Cover photo: Djamel Ouahrani

ISBN 978-91-87866-33-3
ISSN 1404-286X
ISRN LUHDM-R--12--SE

This report has been published with financial support from
the Swedish International Development Cooperation Agency (Sida)

Printed in Sweden by Media-Tryck, Lund, 2009

This report can be ordered from:

Housing Development
& Management
Lund University
PO Box 118
SE-221 00 Lund, Sweden

Tel.: +46-46 222 9761
Fax: +46-46 222 8181
e-mail: hdm@lth.se
Homepage: <http://www.hdm.lth.se>

Building Research Centre
Royal Scientific Society
PO Box 1438
11941 Al-Jubaiha
Jordan

Tel: +962-6 534 4701
Fax: +962-6 534 7399
e-mail: rssinfo@rss.gov.jo
Homepage: <http://www.rss.gov.jo>

Climate Conscious Architecture and Urban Design in Jordan

Towards energy efficient buildings
and improved urban microclimate

**Housing Development &
Management**

Erik Johansson (editor)

Djamel Ouahrani (editor)

Royal Scientific Society

Hala Shaker Al-Asir

Tala Awadallah

**Energy &
Building Design**

Åke Blomsterberg

Håkan Håkansson

Bengt Hellström

Hasse Kvist



Contents

Contents	5
Summary	7
1 Introduction	9
1.1 The climate of Jordan	9
1.2 Objective of the project	10
1.3 The process of the project	13
1.4 Project participants	15
1.5 Presentation of the report	19
2 Overview of the construction sector in Jordan	21
2.1 Construction and property services market in Jordan	21
2.2 Characteristics of the market	22
3 Energy use, thermal comfort and urban climate	27
3.1 Energy costs in dwellings in Amman	27
3.2 Thermal comfort	31
3.3 Urban microclimate and outdoor thermal comfort	41
4 Testing as support for energy efficiency in buildings	49
4.1 Measurement review and advice for the future	49
4.2 Measurement of g-values and heat resistances on solar shutters	58
4.3 Ventilation measurements	63
5 Software development as support for energy efficiency of buildings	67
5.1 Background	67
5.2 DEROB-LTH	67
5.3 ParaSol	70
6 Towards a climate conscious design in Jordan	73
6.1 Survey of existing energy codes	73
6.2 Climatic zoning of Jordan	79
6.3 Thermal requirements for Amman	84
6.4 Climate-conscious urban design for Amman	97
7 Conclusions and recommendations	109
7.1 Testing as support for energy efficiency of buildings	109
7.2 Software development as support for energy efficiency of buildings	111
7.3 Thermal requirements for building elements	112
7.4 Climate-conscious urban design	113
8 References	115

Summary

This report is the result of a collaboration between the Royal Scientific Society (RSS) of Jordan and Housing Development & Management and Energy & Building Design at Lund University in Sweden. The overall objective of the project was to define the means and criteria for improving thermal performance and minimising energy use in buildings in Jordan. The project was divided into three main parts, *Theoretical concepts*, *Practical experiments* and *Training and awareness campaign*. This report presents the results of the two first activities.

The *Theoretical concepts* dealt with climate-conscious and energy-efficient design, both at the building and urban level. The main emphasis was on the capital city Amman, where most of the construction in Jordan has taken place in recent years, but the same methods can be applied to other cities of Jordan.

A climatic zoning for Jordan was proposed based on two methods: the classical degree day method for heating and cooling and a complementary method based on computer simulations of a typical building's thermal performance to verify and adjust the climatic zoning.

The thermal requirements for the building elements were limited to apartment buildings, which has been the dominant housing type in the last decade. It was shown that it is possible to achieve good indoor thermal comfort by applying a climate-conscious design without the excessive use of energy in mechanical heating and cooling systems. The optimization process carried out for the climate of Amman found the requirements on thermal transmittance (U-value) for both roofs and walls to be between about 0.5 and 0.7 W/m²K. The optimum window to floor ratio (WFR) for a south oriented main façade was found to be between 12% and 20%. These requirements would allow a total saving in energy for cooling and heating of up to 70% for a typical apartment in Amman.

As for the urban microclimate, this study showed that more shade on the street level is necessary to provide a climate-conscious urban design that takes the hot summer conditions into account. This can be provided through a more compact urban design with higher height-to-width ratios of urban street canyons than those currently applied and through different forms of overhead shading, e.g. arcades and other types of covered walkways. However, the cold season also has to be considered and some wider streets and open public spaces should be designed for solar access. The urban codes of Amman were found to be inappropriate and need to be changed to promote shading of pedestrians.

The *Practical experiments* included both laboratory tests and software development. The laboratory tests included measurements of the totally transmitted solar energy through the window (g-value) and the thermal resistance of Jordanian solar shutters. In addition, the ventilation of a typical apartment in Amman was measured, where the ventilation rate in the winter was found to be as low as 0.31 air changes per hour (ach) due to the low wind speed and the small temperature difference between

indoors and outdoors. The summer rate was as high as 2.38 ach as most of the windows were half opened throughout the day and the night.

Furthermore, cost-effective improvements and possible future tests at the RSS laboratory were suggested. These included tests with the existing twin test rooms, tests of the thermal performance of windows with the existing hot box at RSS, a method for the measurement of solar transmission through windows as well as methods for the measurement of g-value for different combinations of windows and solar shutters. Moreover, testing of the performance of different solar energy systems were proposed including both solar collectors and photo-voltaic systems.

The software tools DEROB-LTH and ParaSol were adapted to Jordanian conditions. DEROB-LTH now allows to simulate both mechanically and naturally ventilated buildings and to schedule leakages through opened windows and between internal volumes. A more advanced scheduling function has been developed to monitor heating, ventilation and air-conditioning. In ParaSol, the Jordanian type of window shutters has been included and the range of possible U-values for the external wall has been extended to 1.5 W/m²K.

These theoretical concepts and practical experiments support the recommendations suggested in this report towards the construction of more energy efficient buildings and an improved urban microclimate in Jordan.

1 Introduction

Jordan is almost totally dependent on imported oil and natural gas. Due to different geopolitical reasons, energy prices used to be comparatively low, however since 2003 the subsidies on fuels such as diesel and kerosene have been lifted gradually resulting in a sharp price increase. Electricity prices have also increased substantially in recent years following more or less the prices of the international market. As the demand for energy is increasing steadily in Jordan, future energy prices are likely to continue to increase.

In general, it has not been a priority or obligation to design climate adapted buildings, consequently a high amount of energy is used for heating and cooling buildings. The actual use of air conditioning systems is more common in administrative buildings, hotels and high standard residences. However energy use is likely to increase for the majority of the population, whilst thermal comfort will get worse due to the high energy prices.

Large parts of Jordan have a favourable climate in terms of number of sunshine hours, intensity of solar radiation, large diurnal air temperature variations and low humidity. Hence it is possible to achieve good indoor comfort without an excessive use of energy by applying a climate-conscious design. Such design however, requires increased knowledge among architects, engineers and decisions makers as well as a change of current building techniques and architectural design. An important prerequisite is to have good laboratory facilities and testing methods. Energy codes will also play a crucial role in reducing energy use and increase thermal comfort in buildings. Urban design aspects, such as height and the positioning of buildings as well as a provision of shade are also important; the enhancement of urban microclimate will have positive effects on both energy use in buildings and outdoor thermal comfort of pedestrians.

1.1 The climate of Jordan

Jordan can be divided into three physiographic regions: the Rift Valley in the west, the highlands in the centre and the desert in the east, see Fig.1.1.1.

The agricultural Rift Valley runs along the entire western length of Jordan at an altitude of below 600 m. It encompasses the Jordan Valley, the Dead Sea (the lowest point on earth at 400 m below sea level), Wadi Araba and in the south, Aqaba, which is a popular tropical resort surrounded by mountains. Aqaba enjoys a warm, sunny climate throughout the year, with average temperatures from 15.6°C in January to 32.5°C in July.

The central highlands comprise of mountainous and hilly regions that run through Jordan from north to south, with varying altitudes of 600 to

1600 m. This is the most densely populated region, including the capital city Amman, and other major cities such as Irbid, Zarqa, Karak, Ma'an and Petra. The climate of this region is characterised by hot summers and fairly cold winters. The average temperature in Amman ranges from 8.1°C in January to 25.1°C in July.

The semi-arid desert region in east comprise of nearly two-thirds of the area of Jordan. The climate varies dramatically between day and night as well as between the summer and winter seasons. Summers are hot, dry and windy where temperatures can exceed 40°C, while winter nights can be bitterly cold, dry and windy.

This distinct variation in climate within Jordan advocates for different approaches for energy efficient building. In the highlands the heating season is dominant whereas in the Rift Valley and the desert regions the cooling season is dominant.



Fig.1.1.1 Map of Jordan with the major cities.

1.2 Objective of the project

This report is the result of a technical collaboration between the Royal Scientific Society (RSS) of Jordan and Housing Development and Management (HDM) of Lund University, Sweden. The division of Energy and Building Design (EBD) of Lund University has participated as a sub-consultant. The project actors are described in Section 1.4.

The overall objective of the project was to define the means and criteria for improving thermal performance and minimising energy use in

buildings in Jordan. To achieve this goal different strategies were used. The project was divided into three main parts:

1. Theoretical concepts
2. Practical experiments
3. Training and awareness campaign

1.2.1 Theoretical concepts

The aim of this part of the project was to develop a climate-conscious and energy-efficient design, both at the building and urban level. This included the following objectives:

- Definition of acceptable limits of thermal comfort for different climate zones considering both actively climatized and passive (naturally ventilated) buildings
- Review of existing climatic zones in Jordan and suggestion for a new zoning based on building performance
- Recommendations regarding adequate thermal performance of different building components including windows
- Definition of key parameters that affect the urban microclimate and recommendations for an urban design which provides outdoor thermal comfort for pedestrians both in summer and winter.

The aim of the theoretical concepts was also to provide technical support to the RSS in order to increase knowledge in climate adapted buildings and thermal comfort. This included the assistance in the preparation and upgrading of building codes, guidelines and handbooks.

It was hoped that the outcome of this activity will set guidelines for architects and engineers in Jordan to follow and to ensure an easier application of the energy code.

1.2.2 Practical experiments

The aim of this part was to improve laboratory techniques at the RSS and to adapt two existing software tools to Jordanian conditions.

Laboratory techniques

The aim of this part was to monitor and supervise the analysis of test results including the following:

- Review of measurement and analysis methods previously carried out at the RSS
- Monitor experiments to be carried out at the RSS to ensure that the most appropriate methods and procedures are followed
- Laboratory testing of g-values of shading devices in Sweden using a solar simulator
- Measurement of ventilation rates in a typical Jordanian apartment in both summer and winter

- Defining recommendations for future laboratory tests

Software development

The aim of this part was to adapt two design tools used in the project, Derob-LTH and ParaSol, to the Jordanian context including:

- Jordanian building elements and materials
- Natural ventilation of buildings
- Jordanian types of window shutters

1.2.3 Training and awareness campaign

The objective of this activity was to achieve a more widespread knowledge about climatically adapted and energy efficient construction in Jordan by including both training of professionals in climatic design and preparing material for an awareness campaign.

Training of professionals

The aim of the training activity was to transfer the knowledge and responsibility to the RSS in order to train Jordanian architects and engineers. To achieve this goal the training activity was divided into three steps:

1. Training at HDM of a small RSS team consisting of architects and civil and mechanical engineers in climatic design and energy efficient building
2. Training at the RSS of a selected group of professionals from key institutions and design offices in Jordan to increase their understanding of climatic design and energy efficient buildings
3. Training at the RSS of “key” architects and engineers with current or future responsibility for climate issues within their institutes

Awareness campaign

The aim of this activity was to achieve a wider dissemination of the concepts, tools and general consciousness about sustainable building design, thermal comfort and energy saving. It also aimed to highlight the importance of understanding the building codes and to convince professionals and the public of the benefits of reaching a higher level of thermal comfort and energy saving. It included the following activities:

- Seminar for professionals presenting the main outcomes of the project in order to increase the understanding and to discuss the importance of climatic design and energy saving measures
- Layout of a brochure aimed at designers, builders and users which should describe easily understood methods to improve thermal comfort and to achieve energy efficiency

1.3 The process of the project

This collaborative project was initiated by the Building Research Centre (BRC) at the Royal Scientific Society (RSS) of Jordan in 2004. The project began in February 2005 and was completed in March 2009. The respective teams from Lund University and the RSS were as follows from the start to the completion of the project (see also Section 1.4):

2005	2006	2007	2008
<i>Royal Scientific Society</i>			
Arch. Hala Al-Asir	Arch. Hala Al-Asir	Arch. Hala Al-Asir	Arch. Hala Al-Asir
Arch. Tala Awadallah	Arch. Tala Awadallah	Arch. Tala Awadallah	Arch. Tala Awadallah
Eng. Yasmeen Obaidat	Eng. Yasmeen Obaidat	Eng. Yasmeen Obaidat	Eng. Naela Al-Daoud
Eng. Nidal Yacoub	Eng. Nidal Yacoub	Eng. Nidal Yacoub	Eng. Nidal Yacoub
Eng. Haitham Adas	Eng. Haitham Adas	Eng. Haitham Adas	Eng. Haitham Adas
Eng. Nizar Qaqish	Eng. Nizar Qaqish	Eng. Nizar Qaqish	Eng. Nizar Qaqish
Eng. Ahmed Mhanna			
<i>Lund University</i>			
Dr. Hans Rosenlund	Dr. Hans Rosenlund		
Dr. Djamel Ouahrani	Dr. Djamel Ouahrani	Dr. Djamel Ouahrani	Dr. Djamel Ouahrani
Erik Johansson	Erik Johansson	Dr. Erik Johansson	Dr. Erik Johansson
Dr. Helena Bülow-Hübe			
Dr. Åke Blomsterberg	Dr. Åke Blomsterberg	Dr. Åke Blomsterberg	Dr. Åke Blomsterberg
Dr. Håkan Håkansson	Dr. Håkan Håkansson	Dr. Håkan Håkansson	Dr. Håkan Håkansson
Bengt Hellström	Dr. Bengt Hellström	Dr. Bengt Hellström	Dr. Bengt Hellström
Hasse Kvist	Hasse Kvist	Hasse Kvist	Hasse Kvist

Project managers are marked in bold and partly involved persons in grey

The three main parts of the project described below were carried out simultaneously throughout the project period.

1.3.1 Theoretical concepts

The theoretical concepts part was crucial for the project since a new building code regulating the thermal insulation of the building elements in Jordan was being prepared by the RSS. This project was seen as a major contribution to this work.

This part of the project was performed in close collaboration between Housing Development and Management (HDM) and the RSS. Some of the activities had the focus on the whole of Jordan, whereas other activities concentrated on Amman. In the latter case, the methods developed can be applied by the RSS on other cities in the other climatic zones in the future. The role of the Swedish consultant was also to monitor and supervise the analysis of the results.

The proposal for a new climatic zoning for Jordanian buildings was made using both the classical degree days method and a computer simulation method based on the energy usage in buildings.

Suggestions of the limits of thermal comfort for Jordan, including both passive (naturally ventilated) buildings and actively climatized buildings, were made.

The optimum U-values for building elements for apartment buildings in Amman were found using extensive computer simulations which considered both the winter and summer seasons. This activity also served as demonstration for a method that can be used for other types of buildings in the whole Kingdom of Jordan.

The recommendations for a climate-conscious urban design for the city of Amman were based on computer simulations using an advanced simulation tool.

1.3.2 Practical experiments

The practical experimental part of the project dealt with both measurement techniques and software development.

Previous laboratory measurement and analysis methods performed at the RSS were reviewed and proposals were made for future testing methods at the RSS in Jordan.

Jordanian window shutters were tested with the solar simulator in the laboratory of EBD at Lund University. The laboratory work was educational for the RSS staff and provided valuable measurement data of the g-values for four shutter types commonly used in Jordan. It was planned to test other types of shutters but it was difficult to obtain samples as Jordanian shutters are not subject to quality control and certification. Thus retailers of these products were reticent to have their product tested.

Measurement of ventilation using the tracer gas technique was performed in a typical Jordanian apartment to achieve values of air changes for both the summer and winter.

Two software tools were used in the project and were adapted to Jordanian conditions. DEROB-LTH was used to simulate the indoor climate and energy use of buildings, and ParaSol was used to simulate the performance of shading devices of windows. DEROB-LTH was adapted to include the possibility to study naturally ventilated (passive) buildings. In the ParaSol programme, the possibility to simulate Jordanian types of shutters was added. Other improvements to these softwares not specifically related to the project were also performed

1.3.3 Training and awareness campaign

The training part of the project constituted a major activity with good progress, as HDM is well acquainted with similar training programmes. Four training sessions were carried out; one in Sweden and three in Jordan. The first training session at HDM was for the members of the RSS team to learn more about the main concepts, so that they could act as trainers in subsequent training programmes. The other three sessions were thus carried out by the RSS in Jordan for around 20 professionals in

each course. During these sessions the teaching responsibility was gradually taken over by RSS.

Additionally, some RSS staff members were trained in how to perform measurements of indoor climate and thermal performance of buildings.

The main outcomes of the project were presented and discussed at a final seminar held at RSS on 28 August 2008. The awareness campaign consisted of the layout of a brochure highlighting the different aspects to consider when making buildings in Jordan more energy efficient. This applied to both existing and future buildings.

1.4 Project participants

The project presented in this report was a collaboration between the Royal Scientific Society of Jordan (RSS) and Housing Development and Management (HDM) of Lund University, Sweden. RSS' part of the project was carried out by the Building Research Centre (BRC). The division of Energy and Building Design of Lund University acted as a sub-consultant to HDM.

The Jordanian part of the project was partly financed by the Higher Council of Science and Technology, and the rest by the Royal Scientific Society, who realised the urgency and importance of the subject. The Swedish part was funded by the Swedish International Development Cooperation Agency (Sida).

Below is a description of the project actors.

1.4.1 Building Research Centre

The Building Research Centre (BRC) is one of the technical centres of the Royal Scientific Society (RSS). The scope of its work covers many fields related to the development process in Jordan. The organization enjoys financial and administrative independence and has the flexibility to adapt its structure to fit the ever-changing needs of the Society.

The BRC is staffed by professionals with in-depth knowledge of the technological needs of the construction industry in Jordan. With over 30 specialized engineers and 11 qualified and equipped laboratories, BRC offers services covering the inter-related fields of applied research, architectural and structural design, construction supervision, consultations, testing, standards development, specialized training, and building technology transfer.

The BRC plans, advises, coordinates, and carries out testing, analysis, design, construction supervision, training, and calibration activities. All these services utilize modern equipment, specialized software (including GIS, SAP 2000 NL, and AutoCAD) and a sound technical platform to run a computer network connected to the Internet.

Specialized consulting services benefit a broad sector in the construction industry concerned with civil, architectural, and electro-mechanical works. There are many examples of studies and investigations

performed to assess the durability and structural behaviour of building materials and systems, upgrade and retrofit existing structures, evaluate and preserve urban fabric, develop schemes to reduce risk to natural disasters, and develop new residential and industrial sites.

In its mission statement, the BRC strives to be a premier promoter of the construction industry through its value-added specialized consulting and testing services, applied research, standards development, training, and building technology innovation. BRC provides consulting and technical services associated with architectural design, and engineering research and practice, including:

- Cultural heritage; conservation and rehabilitation
- Climatic design, building physics, insulating materials
- Earthquake engineering and seismology
- Advanced composite materials
- Restoration and rehabilitation of damaged structures and buildings
- Water harvesting technologies
- Precast low cost building system
- Concrete technology
- Mortar technologies and applications for restoration of cultural heritage buildings
- GIS applications
- Training

The following RSS staff have contributed to the project:

Dr. Khaled Kahhaleh	Vice President of RSS, former Director of BRC
Dr. Tareq Al-Hadid	Director of BRC
Tala Awadallah	Architect, BRC, Second project manager
Hala Al-Asir	Architect, BRC, First project manager
Yasmeen Obaidat	Civil engineer, BRC
Ahmed Mhanna	Civil engineer, BRC
Nizar Qaqish	Civil engineer, BRC
Nidal Yaquob	Mechanical engineer, National Energy Research Centre
Haitham Adas	Mechanical engineer, National Energy Research Centre
Naela Al-Daoud	Civil engineer, BRC

1.4.2 Housing Development & Management

Housing Development & Management (HDM) is part of the department for Architecture and Built Environment in the Faculty of Engineering, Lund University, Sweden.

HDM undertakes education and research in housing from an international perspective: planning, design, creation, use and management, and the relationship between the dwelling and its surroundings from neighbourhood to city level. The aim is to understand how to improve the processes leading to good housing and sustainable development, especially for the poor.

HDM organises undergraduate courses, postgraduate courses as part of the international training programme sponsored by the Swedish International Development Cooperation Agency (Sida) and doctoral research. The department is responsible for PROMESHA, a capacity development programme in Latin America for all the actors in the housing sector.

HDM's current research areas include:

- Housing improvement and local development
- Gender aspects in planning and design of housing and built environment
- Housing segregation
- Risk management for buildings in regions with natural disasters
- Influence of urban design on microclimate and thermal comfort around buildings
- Building design with consideration for climate, comfort and energy use
- Environmentally-aware and cost efficient construction

The research area *Influence of urban design on microclimate and thermal comfort around buildings* includes studies of how to create a comfortable climate between buildings in an urban environment through the conscious design of streets, building heights, etc. The research is based on extensive measurements and computer simulation.

The research area *Building design with consideration for climate, comfort and energy use* includes studies of increasing indoor comfort through good building design, and reducing the energy needed for cooling or heating. The research is based on measurements, computer simulation and experimental buildings. The work is mainly in collaboration with institutions in North Africa and Jordan.

HDM offers international training programme *Shelter Design & Development*, which runs two times annually with a course period in Lund and a regional continuation. HDM cooperates with the Department of Architectural Conservation and Restoration on the international training programme *Conservation & Management of Historic Buildings*.

HDM teaches the Housing Specialization in the 12 months Master of Arts in Urban Management and Development organized by the Institute for Housing and Urban Development Studies, Erasmus University, in the Netherlands.

The following HDM staff have contributed to the project:

Johnny Åstrand	Director of HDM
Dr. Djamel Ouahrani	Architect, project manager
Dr. Hans Rosenlund	Architect, former project manager
Dr. Erik Johansson	Civil engineer

1.4.3 Energy & Building Design

Energy & Building Design (EBD) is a division of the Department of Architecture and Built Environment in the Faculty of Engineering, Lund University, Sweden.

EBD is doing research in the areas of

- Energy efficient buildings
- Glazed buildings
- Solar shadings
- Light control
- Thermal comfort and occupancy aspects
- Active solar energy for electricity (PV-cells) and heating.

EBD works with the development of passive houses in Sweden. Passive houses are low energy buildings that fulfil certain specified requirements. They are very well insulated, airtight and have a mechanical, balanced ventilation system with a heat recovery system. The space heating demand should be low enough to enable heat to be distributed through the ventilation system.

In a recent research project on glazed office buildings, the possibility to use glazed façades in an office building without using a vast amount of energy was investigated.

EBD has several research projects on solar shadings. Different kinds of solar shadings have been characterized through measurements, using hot-boxes and a solar simulator. The computer software 'ParaSol' has been developed specialising in the calculations and yearly simulations of different kinds of solar shadings and windows in a room module. ParaSol is based on DEROB-LTH, a building simulation program that is being continuously developed at EBD.

The research in active solar energy includes both thermal systems (for hot water or heating) and photo voltaic systems (for electricity production). The main work has been on concentrating systems and building integration of collectors.

EBD gives courses related to the research areas. Courses on energy efficient buildings and active solar energy are taught on a regular basis. A new master program specialised in the design of energy efficient buildings is planned to commence in 2010.

Further information on EBD can be found at www.ebd.lth.se

Publications can be downloaded from www.ebd.lth.se/publikationer

ParaSol can be downloaded free of charge from www.parasol.se

The following EBD staff have contributed to the project:

Dr. Åke Blomsterberg	Civil engineer
Dr. Helena Bülow Hüb	Civil engineer
Dr. Bengt Hellström	Mechanical engineer
Dr. Håkan Håkansson	Civil engineer
Hasse Kvist	BSc Mathematics

1.5 Presentation of the report

This report presents the results of the first and second parts of the project *Theoretical concepts* and *Practical experiments* described in Sections 1.3.1 and 1.3.2 above.

In Chapter 1 the background and objectives of the project are presented. This chapter also describes how the project was carried out and evolved. It also contains the descriptions of the project participants.

Chapter 2 *Overview of the construction sector in Jordan* describes the construction sector in Jordan in regards to the market, building activity, availability of building materials as well as contractors and consultants.

Chapter 3 *Energy use, thermal comfort and urban climate* presents statistics on energy use in Jordan, discusses the concept of thermal comfort, including limits of thermal comfort zones applicable to Jordan, and introduces the concept of urban microclimate.

The main results from the project are presented in Chapters 4, 5 and 6. Chapter 4 *Testing as support for energy efficiency in buildings* contains a review of measurements performed by RSS, solar laboratory tests on Jordanian shutters and ventilation measurements in a typical apartment.

Chapter 5 *Software development as support for energy efficiency in buildings* describes the adaptation to Jordanian conditions of existing software tools that has been carried out within the project.

Chapter 6 *Towards climate-conscious design in Jordan* presents a survey of existing energy codes followed by a suggested climate zoning of Jordan. Furthermore this chapter contains recommendations on thermal requirements for apartment buildings in Amman as well as recommendations on climate-conscious urban design in Amman.

The report ends with Chapter 7 *Conclusions and recommendations* which contains the most important conclusions and recommendations of the project.

The following persons have contributed to the report:

Arch. Hala Al-Asir, BRC, Chapter 2 and Chapter 6 (Section 6.4)

Arch. Tala Awadallah, BRC, Chapter 2.

Dr. Åke Blomsterberg, EBD, Chapter 4 (Section 4.3) and Chapter 7 (Section 7.2).

Dr. Håkan Håkansson, EBD, Chapter 4 (Sections 4.1 and 4.2) and Chapter 7 (Section 7.2).

Dr. Bengt Hellström, EBD, Chapter 5 and Chapter 7 (Section 7.1).

Ms. Yatwan Hui, language editing (all chapters) and graphics (Chapter 6).

Dr. Erik Johansson, HDM, Chapter 1, Chapter 3 (Sections 3.2 and 3.3), Chapter 6 (Sections 6.1 and 6.4) and Chapter 7 (Section 7.4).

Mr. Hasse Kvist, EBD, Chapter 5 and Chapter 7 (Section 7.1).

Dr. Djamel Ouahrani, HDM, Chapter 1, Chapter 3 (Section 3.1), Chapter 6 (Sections 6.2 and 6.3) and Chapter 7 (Section 7.3).

2 Overview of the construction sector in Jordan

2.1 Construction and property services market in Jordan

During the development process Jordan has invested a considerable amount of its scarce financial resources in the construction industry, building houses, hotels, banks, schools, etc. for both the public and private sectors. It is expected that this sector will expand even more in the coming years due to the growing need for good quality housing in Jordan for the expected population of about 6 millions in 2009. The construction sector accounts for 15% of the GDP and about 10% of the labour force.

The total value of construction works in the public sector in 2003 was 190.5 million Jordanian dinars. The total value of construction works in the private sector in 2003 was 1 410 million Jordanian dinars, with 7.5 million m² licensed. The number of engineering offices registered at the Jordan Engineers Association was 1102 offices.

Looking to the future, Jordan's construction industry is increasingly collaborating with international partners. Many joint ventures are being formed between international consultants and contractors and local firms in order to improve competitiveness and capitalise on increased investment on infrastructural projects such as airports, hotels, refineries, communications and broadcasting ventures. International firms are providing specialized technical expertise, while local firms are contributing with their technical services.

Jordanian consultancy firms are also becoming increasingly active abroad in various regional projects, especially in Iraq, Yemen, Saudi Arabia, the Palestinian National Authority territories (PNA) and the United Arabs Emirates (UAE). Jordan's construction industry is expected to be one of the prime beneficiaries of an eventual peace agreement between Israel and the PNA. Widespread re-development of the infrastructure in the PNA is required, and Jordan's construction industry is well-positioned, both geographically and politically, to capitalise on this opportunity. At present there are more than 3000 registered Jordanian consultants and engineers working in the West Bank and Gaza. Likewise, the eventual lifting of sanctions promises to spark an infrastructural investment boom in Iraq, and Jordan's construction sector is poised to benefit from this opportunity as well.

Modern construction technology has been incrementally used including pre-cast concrete, environmental control systems, and intelligent building management systems.

Infrastructure projects requiring exceptional expertise ranging from airports, hotels, refineries, and communication and broadcasting projects are leading to collaborations with international partners. Many joint ventures are being formed between international consultants and contractors and local firms in order to improve competitiveness and capitalize on the market. International firms are providing the special technical know-how local firms are contributing with their technical services. Encouraged by the prospect of peace, an increasing number of international consultants and contractors are showing interest in the region.

The construction sector not only provides current employment for manual labourers and investment into the economy, but indicates future economic growth. Many of the current construction projects consist of factories, hotels and other buildings that will provide employment for other Jordanians.

The Jordanian Government is encouraging investment in the tourism sector by granting investors full exemptions on import duties and taxes for material and products used on the project. There are over 15 five-star and 4-star hotels under construction mainly in the capital Amman, the Dead Sea area and in the Red Sea resort city of Aqaba. Investment in each of these new tourist development projects ranges between US\$20 million and US\$350 million.

In addition to hotels and tourist villages, several hospitals, shopping centres, universities, commercial buildings and private residential buildings are under construction and at the design stage.

The infrastructure in Jordan, particularly in the water, energy and transport sectors, is expanding and several fertiliser and chemical processing plants are underway in Jordan.

2.2 Characteristics of the market

2.2.1 Building activity

There has been much construction activity in Jordan, from 1 million m² of licensed area for construction in 2000, to 2.14 million m² in 2007 and 1.78 million m² in 2008. This is mainly attributed to residential buildings.

The two main areas where future development in the hotel and leisure sector will take place are by the Dead Sea and in the Red Sea resort city of Aqaba. The Dead Sea, which is the lowest point on earth, is rich with minerals that are known for their curative powers. The Jordan Valley Authority (JVA) owns the land at the Dead Sea and regulates tourist investments in that area. The JVA prepared a Master Plan in 1997 for the development of the 60 km eastern shoreline. The plan called for the

provision of 3 major development areas to accommodate a total of 34,000 bed units by 2010, in addition to the required infrastructure such as water and sewer pipes, a power sub-station, telecommunication links and road networks. Work on developing the basic infrastructure and utilities in the Dead Sea region has already proceeded. Since the beginning of the millennium JVA has invested over US\$20 million in the infrastructure development to serve the investors in the Dead Sea region.

Construction activity is also taking place in the Red Sea city of Aqaba. The Aqaba Special Economic Zone Authority (ASEZA) aims to expand hotel facilities in the Aqaba region to accommodate and cater for the anticipated increase in tourists. ASEZA also plans to expand recreational and sports facilities and construct commercial and business centres. Its development plans include the allocations of four 5-star hotels and three 4-star hotels (5080 beds in total), in addition to various facilities including tourist villages, motels, restaurants, swimming pools, private beaches, camping sites, sports facilities and others. In May 2000 ASEZA invited offers for a water theme park, an underwater observatory and a 5-star hotel project on the southern coast of Aqaba.

New international hotel chains have entered the market in the last two years including the Hyatt, Holiday Inn of Bass Resorts and Hotels, Sheraton of Starwood, the Swiss chain Mövenpick, Four Seasons, ACCOR of France, Howard Johnson and others.

2.2.2 Building materials

Jordan has one of the lowest land and construction costs in the region. Locally produced quality materials are available at competitive and stable prices, thus increasing the profits of this industry. Stone is quarried locally, cement is produced locally and steel reinforcement bars are manufactured locally from imported steel. Jordan also produces its own aggregates, aluminium profiles, terrazzo tiles, most kinds of paint, certain construction chemicals, ceramic tiles, sanitary fixtures, kitchen cabinets, timber joinery, air conditioning and heating equipment, electrical items, elevators, pipes and wires. These are all available at competitive prices, providing savings in customs duties and overseas transportation.

Other building materials are imported from around the world.

2.2.3 Engineering contractors and consultants

Jordan's high-calibre labour force makes it well-equipped to support a dynamic construction industry. In 2008 there were 75,730 registered engineers and architects in the country, of which 28% were civil, 35% electrical and 21% mechanical engineers.

Jordanian contractors are experienced in many building and infrastructure projects. The number of contractors in Jordan in 2003, according to their classification, are shown in Table 2.2.1.

Table 2.2.1 Number of contractors in Jordan according to their classification in 2003

<i>Contractors Classification</i>	<i>Number of Contractors</i>
Classification 1	232
Classification 2	140
Classification 3	258
Classification 4	356
Classification 5	489
Total	1479

Approximately 20% of registered engineers graduated from Jordanian universities, and the remaining around 80% have graduated from academic institutions in other countries due to the limited capacity of local universities. Of the engineers who studied abroad, approximately 26% graduated from Arab countries, 30% from Europe and 12% from the US.

Jordanian consultancy firms are also becoming increasingly active abroad in various regional projects, especially in Iraq, Yemen, Saudi Arabia, the territories of the Palestinian National Authority and the United Arab Emirates. At present, there are more than 3000 registered Jordanian consultants and engineers working in the West Bank and Gaza. Jordan's construction sector is poised to benefit from rebuilding the infrastructural in Iraq as well.

Table 2.2.2 Gross domestic product and factor income by type of economic activity 1998 (in million Jordanian Dinars)

<i>Economic activity</i>	<i>Gross output</i>	<i>Intermediate consumption</i>	<i>Gross domestic product</i>	<i>Compensation of employees</i>	<i>Depreciation</i>
Construction sector	767.4	571.9	195.5	164.0	25.4
Percentage	9%	14%	5%	14%	5%

Table 2.2.3 Employees and enterprises by economic activity and size group of employment for 2006 (both public and private sectors)

Economic activity	No. of employees and establishments	Size group of employment					
		Total	1-4	5-19	20-49	50-99	≥100
Mining and quarrying	Employees	6056	43	640	702	166	4506
	Establishments	121	11	76	27	2	4
Manufacturing	Employees	169805	34600	28051	14339	10897	81917
	Establishments	20090	15449	3809	467	152	214
Electricity, gas and water supplies	Employees	14226	0	16	0	0	14210
	Establishments	8	0	1	0	0	7
Constructions	Employees	27473	1376	6103	7563	3762	8669
	Establishments	1531	565	631	245	56	34
Wholesale and retail trade and repair of motor vehicles and motorcycles and personal and household goods	Employees	193471	142042	24129	7548	5232	14519
	Establishments	89146	85425	3302	282	72	65
Hotels and restaurants	Employees	40296	8798	13953	3522	2131	11893
	Establishments	6625	4642	1778	132	30	44
Transport, storage and communications	Employees	29521	2744	4448	2893	1773	17664
	Establishments	1740	1040	553	92	25	30
Financial intermediation	Employees	21524	546	1205	1379	1621	16773
	Establishments	445	209	140	40	22	33
Real estate, renting and business activities	Employees	52246	19577	8075	3476	1810	19308
	Establishments	10838	9518	1145	110	26	38
Public administration and compulsory social security	Employees	83826	0	17	977	3083	79749
	Establishments	181	0	1	28	43	109
Education	Employees	154787	1774	9676	8045	5090	130201
	Establishments	2098	554	1092	281	69	102
Health and social work	Employees	54760	7587	4573	1366	1745	39489
	Establishments	4428	3867	457	44	25	35
Other community, social and personal service activities	Employees	24566	14134	5212	604	1092	3523
	Establishments	9636	8776	815	19	15	11
Total	Employees	872556	233221	106097	52415	38402	442422
	Establishments	146886	130056	13800	1767	537	726

Source: Dept. of Statistics, Jordan (http://www.dos.gov.jo/owa-user/owa/employment.emp_show_t1)

3 Energy use, thermal comfort and urban climate

3.1 Energy costs in dwellings in Amman

3.1.1 Introduction

The objective of this analysis is to illustrate how energy is used in different types of houses and districts in Jordan. This would highlight priorities that should be taken into consideration in this project of improving energy efficiency in buildings.

Statistical data are provided by the Department of Statistics (DOS) of Jordan. The data analyses are as follows: house type, district, principal source of heating, electricity, diesel heater and gas heater.

The following housing types in Amman were studied:

1. Villa
2. Dar
3. High standard apartments (in buildings > 2 storeys)
4. “Low standard” apartments (mainly in buildings \leq 2 storeys)

This analysis tries to answer the following questions:

1. What is the most dominant type of houses by district?
2. How much energy is used in different types of houses? The data concerning the energy used in terms of kWh is missing but data on energy costs exists which has been used as reference.
3. What will be the impact of higher energy prices on the household economy?

3.1.2 The case of Amman

According to the statistics from the Department of Statistics, the existing housing stock and its energy use in Amman is as follows. The most common house type is the relatively high standard apartment followed by popular houses called Dar, and the third most common is the villa and least common is the “low standard” apartment (see Fig. 3.1.1). This trend seems to continue as the most of the current housing projects are in the construction of high standard apartments.

The new apartments use the most energy in the housing stock, as they are equipped with central heating systems (see Fig. 3.1.2). However figures showing the energy costs are not indicative of the thermal

efficiency of the different housing types as energy use varies with the economic status of the household. It is highly recommended to investigate the accepted thermal comforts of the population living in the different housing types and regions. Due to the higher standard construction of a villa, the expectation of thermal comfort is higher than that in a Dar, which is of a lower standard than a villa.

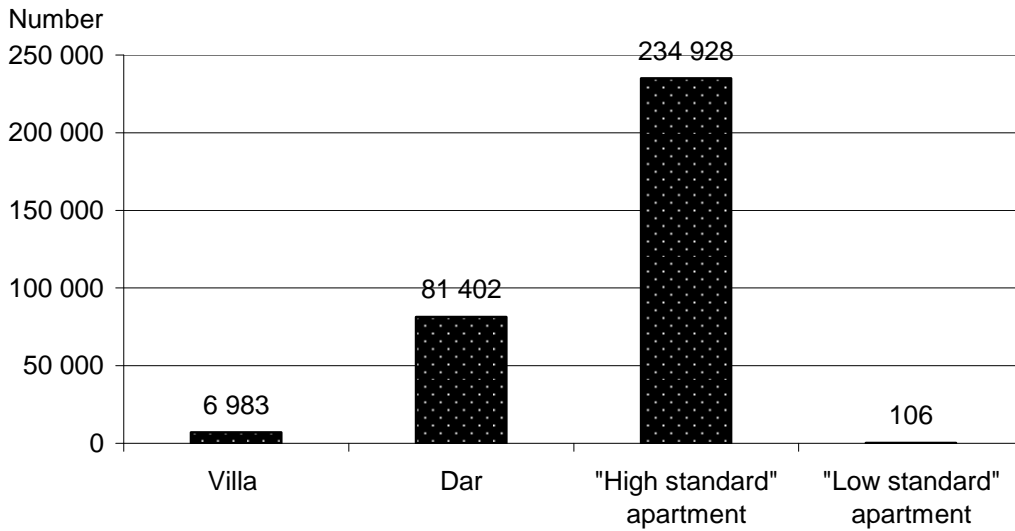

Fig. 3.1.1 Number of houses per housing type in Amman.

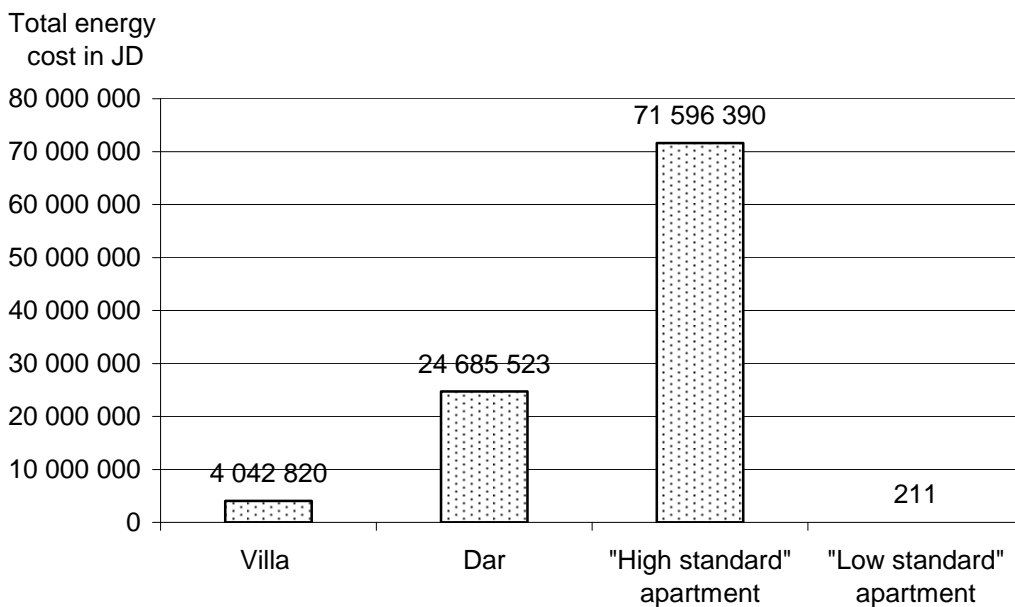

Fig. 3.1.2 Yearly energy cost in Jordanian Dinars (JD) per housing type in Amman

The total energy cost for villas is low. However this figure is incomplete as there is no data for 40% of the villas as they are either not occupied most of the year or not accessible (see Fig. 3.1.3).

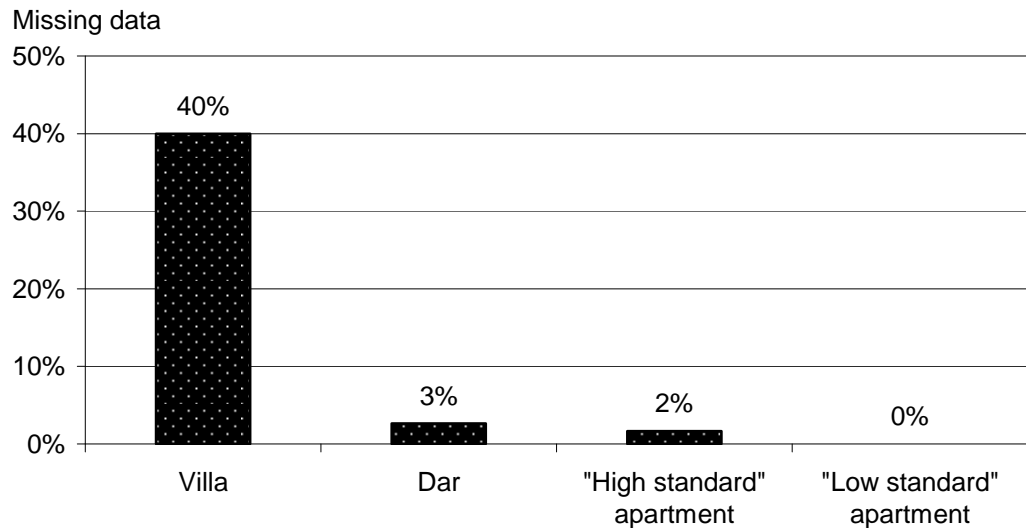

Fig. 3.1.3 Incomplete data on energy cost per housing type in Amman.

In our methodological approach for the optimization of the different thermal elements of construction, a model for houses should be defined. These models will be used in spatial efficacy analysis, thermal parametric analysis and in the final proposal for the thermal norms. Spatial efficacy analysis informs how much the space is used and its construction and running costs. Reducing infrequently used spaces is an aspect of energy saving.

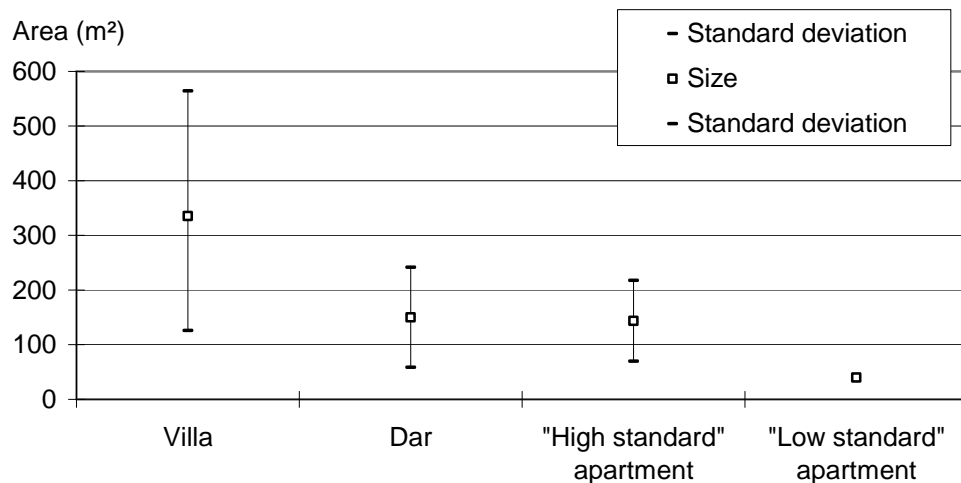

Fig. 3.1.4 Sizes of different types of housing in Amman (average and standard deviation).

Fig. 3.1.4 shows the average size of different house types. The villa has the largest area in m² of the four housing types, though the sizes of the houses and plots vary significantly. Villa construction in Amman is directly linked to the economy of the neighbouring “oil countries” and built for Jordanians working abroad or foreigners. The Dar and “high standard” apartment are similar in size and typology. It is suggested that the principal difference between these two types is the ownership. The Dar is

owned by one large family and the “high standard” apartment building is co-operatively owned by the tenants.

3.1.3 Energy costs as indicator of energy use

Fig. 3.1.5 shows the energy cost per m² of different house types and Fig. 3.1.6 shows the average size and energy costs for different housing types. The energy cost per m² is the only parameter that we actually refer to as indicator of energy efficiency. However, this should only be a primary indicator and not an accurate measurement since the thermal comfort level might be very different in different housing types.

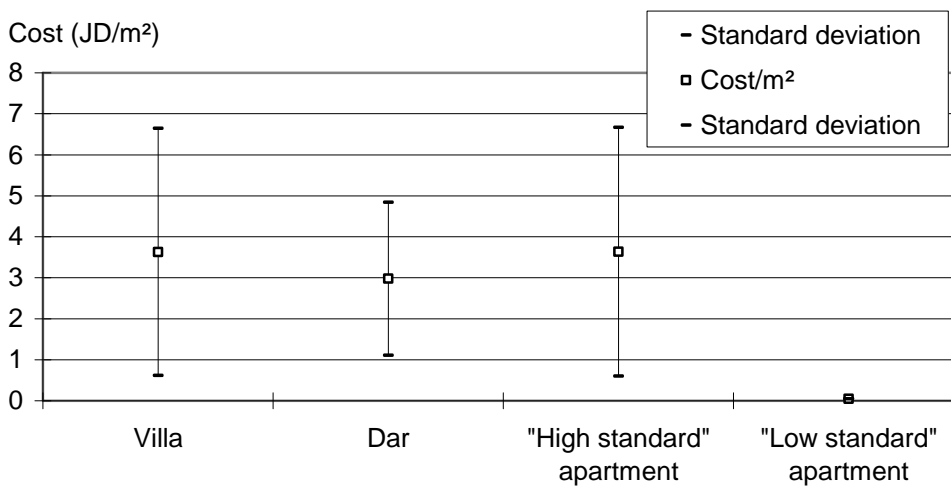

Fig. 3.1.5 Average and standard deviation of yearly energy cost in Jordanian Dinars (JD) per m² for different housing types in Amman

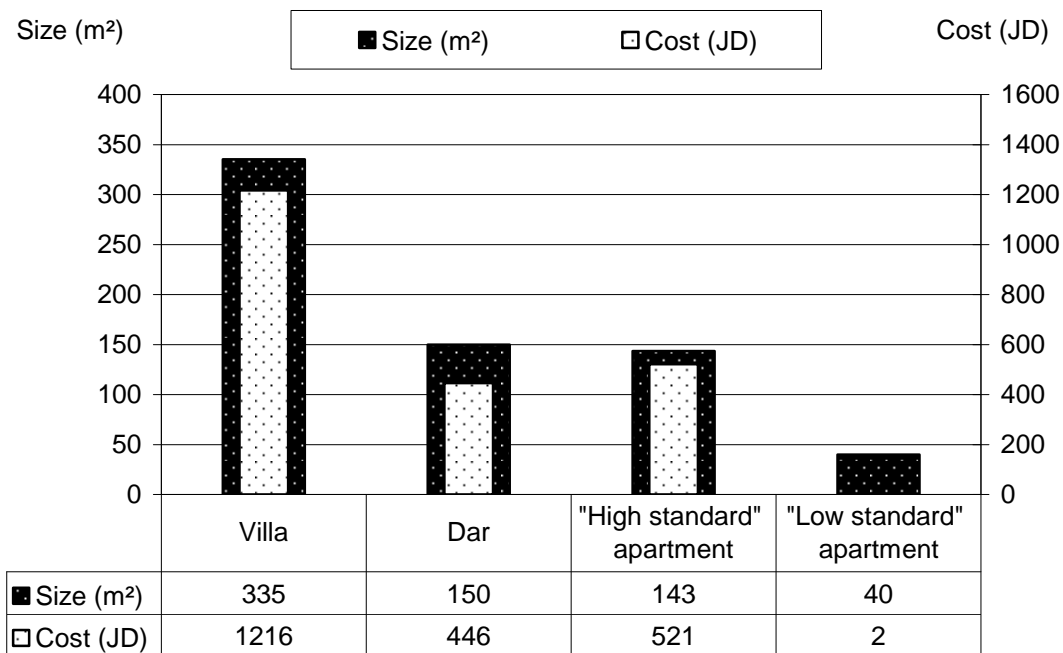

Fig. 3.1.6 Average size and yearly energy cost in Jordanian Dinars (JD) for different housing types in Amman

3.2 Thermal comfort

According to ASHRAE, thermal comfort is defined as the “condition of mind that expresses satisfaction with the thermal environment” (ASHRAE, 1997). Another definition is the absence of thermal discomfort, that is to say, that an individual feels neither too warm nor too cold (McIntyre, 1980). The temperature of this state is referred to as the *neutral temperature*. However, thermal sensation is subjective, meaning that not all people will experience comfort in the same thermal environment. For indoor conditions, comfort zones are typically implemented to satisfy 80% of people. The comfort zone is often expressed as a temperature range around the neutral temperature.

3.2.1 The heat balance of the human body

A good way to illustrate all of the variables that influence thermal comfort, and how these inter-relate, is to study the energy balance of the human body. Many of the most common thermal indices for indoor conditions are based on this heat balance (McIntyre, 1980). The input in the heat balance is the metabolic heat production of the body and the output is the sum of heat losses through *sensible heat flow* from the skin, *evaporation* from the skin and *respiration*. The heat balance can be expressed as (see e.g. McIntyre, 1980; ASHRAE, 1997):

$$M = (R + C) + (E_{dif} + E_{sw}) + (C_{res} + E_{res}) \quad (3.1)$$

where

M is the internal heat production of the human body,

R and C are the radiation and convection heat losses from the outer surface of the clothed body (or exposed skin) respectively,

E_{dif} is heat loss by evaporation of moisture diffused through the skin,

E_{sw} is heat loss through the evaporation of sweat and

C_{res} and E_{res} are the convective and evaporative heat losses through respiration respectively.

From a thermo-regulatory perspective, Eq. 3.1 represents the requirement for thermal comfort, i.e. heat production must equal heat losses (McIntyre 1980). If the body is not in thermal balance its temperature will change and eventually become uncomfortable.

3.2.2 Variables influencing thermal comfort

There are four environmental variables affecting the thermal comfort of the human body:

- air temperature
- radiation

- humidity
- air speed

Additionally, two personal variables influence thermal comfort:

- clothing
- level of activity

However, other personal factors related to adaptation and acclimatisation have proven to affect thermal sensation and are discussed below.

Air temperature

The air temperature is one of the most important climatic factors influencing thermal comfort. Both the body's convective heat loss C and its dry respiration heat loss C_{res} decrease with increasing air temperature.

Radiation

The absorption of solar radiation and the exchange of long-wave radiation strongly affect the state of thermal comfort of the human body. For indoor conditions, the concept of mean radiant temperature (MRT) was developed. This is defined as “the uniform temperature of an imaginary enclosure in which radiant heat transfer from the human body equals the radiant heat transfer in the actual non-uniform enclosure” (ASHRAE 1997). Indoors, where short-wave radiation is normally absent, the body exchanges long-wave radiation with the six room surfaces and the MRT can be calculated by weighting the influence of the temperatures of each surface (see e.g. McIntyre 1980, ASHRAE 1997). For a room a simplified way of calculating the MRT is:

$$MRT = \frac{\sum_{i=1}^n T_{si} \cdot A_i}{\sum_{i=1}^n A_i} \quad (3.2)$$

where

T_{si} = surface temperature of surface i (°C)

A_i = area of surface i (m²)

The radiant heat loss R of the human body decreases with increasing MRT. When MRT is higher than the temperature of the outer surface of the clothed body (or exposed skin), there is a radiative heat gain. Otherwise, R is positive and there is a radiative heat loss.

Air humidity

A change in the humidity of the atmosphere affects thermal sensation in that a person feels warmer, sweatier and less comfortable (McIntyre 1980). Especially in warm conditions, when both convective C and

radiative R heat losses are small, sweat evaporation E_{sw} is an important mechanism in maintaining comfort. When the liquid sweat on the skin surface evaporates, latent heat is extracted from the body and a cooling effect is produced.

According to Givoni (1988) humidity does not influence thermal sensation below a critical level. However, above this level part of the latent heat of vaporisation is taken from the ambient air instead of from the skin. This will lead to more sweat production and thus increased discomfort due to the feeling of excessive skin wetness¹. For subjects with sedentary activity, Givoni (1998) has defined this limit to 80% relative humidity for temperatures up to 25°C.

Air speed

Air speed is a major factor affecting the state of thermal comfort. Both the convective heat loss C and the evaporation of sweat E_{sw} increase with increasing air speed because both the convective and evaporative heat transfer coefficients increase in magnitude (the insulating boundary layer around the body becomes smaller). Strong air movement is thus a disadvantage in cold climates, but a clear advantage in hot climates.

Personal factors

Metabolic heat M depends on the level of activity. The metabolic rates for various activities are shown in Table 3.2.1. Increased clothing insulation leads to a lower temperature difference between the outer surface of the clothed body and the ambient air temperature. Consequently, the convective C and radiative R heat losses decrease with increasing clothing insulation. Examples of thermal insulation for different types of clothing is shown in Table 3.2.2.

Table 3.2.1 *Metabolic rate for adults for various activities expressed in the units met and Watts (W)*

Activity	Metabolic rate	
	met	W
Sleeping	0.7	75
Sitting	1.0	105
Standing, relaxed	1.2	125
Typing	1.2–1.4	125–145
House cleaning	2.0–3.4	210–350
Walking (3–6 km/h)	2.0–3.8	210–400
Heavy machine work	3.5–4.5	370–470
Pick and shovel work	4.0–4.8	420–500

Source: ASHRAE, 1997

¹ Skin wetness is the ratio between the actual and maximum evaporative loss at the skin surface.

Table 3.2.2 Examples of thermal insulation for different types of clothing expressed in the unit clo (1 clo is equal to 0.155 m²K/W)

Clothing	clo
Shorts	0.1
Walking shorts and short-sleeve shirt	0.4
Skirt, short-sleeve shirt and panty hose	0.5
Trousers and shirt	0.6
Sweat pants and sweat shirt	0.7
Trousers, shirt and jacket	1.0
Skirt, long-sleeve shirt, panty hose and long-sleeve sweater or jacket	1.0–1.1
Heavy three-piece business suit	1.5
Heavy suit and woollen over coat	2.0–2.5

Source: ASHRAE, 1997

Psychological factors

Psychological factors also influence thermal comfort. These factors have gained more attention in recent years because discrepancies have been found between predictions using thermal indices and subjective thermal sensation. These discrepancies have been found for both indoors and outdoors thermal comfort perceptions and give evidence to the fact that people adapt to their thermal environment (de Dear and Brager 2002, Emmanuel 2005).

In the hot humid climate of Bangkok in Thailand, Busch (1992) found that people spending most of their time in naturally ventilated (passive) buildings tended to accept higher indoor temperatures than those spending most of their time in air conditioned buildings, see Table 3.2.3. He attributed the results to a difference in “background” experience: people accustomed to cool, air conditioned environments expected, and preferred, it to be colder, whereas people who spent most of their time in warm, non-air conditioned environments expected it to be warm.

Table 3.2.3 Neutral and maximum temperatures in air-conditioned and naturally ventilated offices in Thailand

	$T_{neutral}$	T_{max}
Air-conditioned offices	24.5°C	27°C
Naturally ventilated offices	27.5°C	31°C

Source: Busch, 1992

3.2.3 Thermal comfort indices

A thermal comfort index combines two or more variables into one single index. A great number of indices trying to predict the state of thermal comfort, mainly for indoor applications but also for the outdoors, have been developed (McIntyre 1980, Emmanuel 2005).

Thermal comfort indices for indoors

The most commonly used thermal comfort indices for indoor applications are based on the heat balance of the human body, e.g. the new effective temperature (ET*), the standard effective temperature (SET*), the predicted mean vote (PMV) and the physiologically equivalent temperature (PET). These indices have in common that they take into account all environmental variables influencing thermal comfort and that they have been validated by extensive climate chamber studies establishing the comfort zones.

Both ET* and SET*(expressed in °C) are calculated with the same two-node model, where the heat balance between the environment and a cylinder is calculated in an iterative process until equilibrium is reached, normally after one hour. The difference between them is that SET* also incorporates the level of activity and clothing insulation.

PMV, which is the most widely used thermal comfort index, has proven to provide reliable results for thermal environments close to thermal comfort. Like SET*, the PMV index includes the level of activity and clothing insulation. The PMV values vary from -3 to +3 according to the thermal sensation scale in Table 3.2.4.

These standards have been assumed to be “universal” and thus valid for all building types, all climate zones and all populations. However, field research during the latest decades have shown that they do not always predict the thermal sensation that people actually feel. A common feature is that they often fail to correctly predict the thermal sensation in environments outside the comfort zone or under dynamically changing conditions. According to Oseland and Humphreys (1994) one reason for this is that subjective thermal sensation can be quite different from the physiological state of the body, especially if climatic conditions are not steady or if there are abrupt changes in activity and clothing.

Although the applicability of the indices described above have some limitations, they have also several advantages. For example, they take all environmental variables into account and consequently provide a comprehensive picture of the thermal environment.

3.2.4 Thermal comfort standards

The two most common thermal comfort standards in the world are ISO 7730 and ASHRAE 55. The former is used in Europe whereas the latter is used in North America, East Asia and other places.

ISO 7730

The ISO 7730 standard is based on the PMV index described above. The thermal sensation scale of PMV in Table 3.2.4. The comfort zone of PMV is defined as: $-0.5 \leq \text{PMV} \leq +0.5$. This comfort zone is valid in both summer and winter.

Table 3.2.4 The thermal sensation scale of the PMV index

Sensation	PMV
cold	-3
cool	-2
slightly cool	-1
neutral	0
slightly warm	+1
warm	+2
hot	+3

Source: ISO, 1994

ASHRAE comfort standard 55

The ASHRAE comfort standard 55 is based on the ET* index. The standard has one comfort zone for the summer and another for the winter according to Fig. 3.2.1. The activity, clothing and air speed for the summer and winter comfort zones are shown in Table 3.2.5. It is thus assumed that in summer the clothing insulation is less and the air speed higher than in winter.

Table 3.2.5 The activity, clothing and air speed for the summer and winter comfort zones of ASHRAE comfort standard 55

	Summer	Winter
Activity:	1.2 met	1.2 met
Clothing:	0.5 clo	0.9 clo
Air speed:	0.25 m/s	0.15 m/s

Source: ASHRAE, 1997

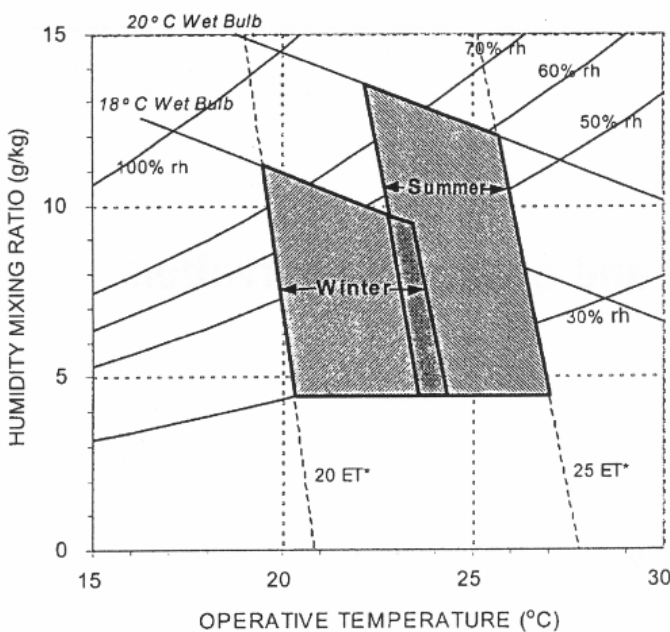

Fig. 3.2.1 Winter and summer comfort zones of ASHRAE standard 55 (ASHRAE, 1997)

In Fig. 3.2.1 the operative temperature (T_{op}) is used. This temperature expresses the combined effect of the air temperature and mean radiant temperature (MRT). It can be calculated as:

$$T_{op} = \frac{T_{air} + MRT}{2} \quad (3.3)$$

As can be seen in Fig. 3.2.1 both the upper and lower levels of the operative temperature depend on the humidity; the lower the relative humidity, the higher the temperature limits. At 50% relative humidity the comfort range of the operative temperature is 20–23.5°C for the winter and 23–26°C in summer.

3.2.5 Adaptive thermal comfort standards

Several field surveys in dwellings, offices etc. conducted over the latest decades have shown that the calculated thermal sensation of indices such as PMV and ET* differs from the actual thermal sensation of interviewed people. The reason is linked to the fact that the existing comfort standards are ignoring important aspects such as:

- Cultural aspects
- Climatic aspects
- Social aspects
- Thermal adaptation

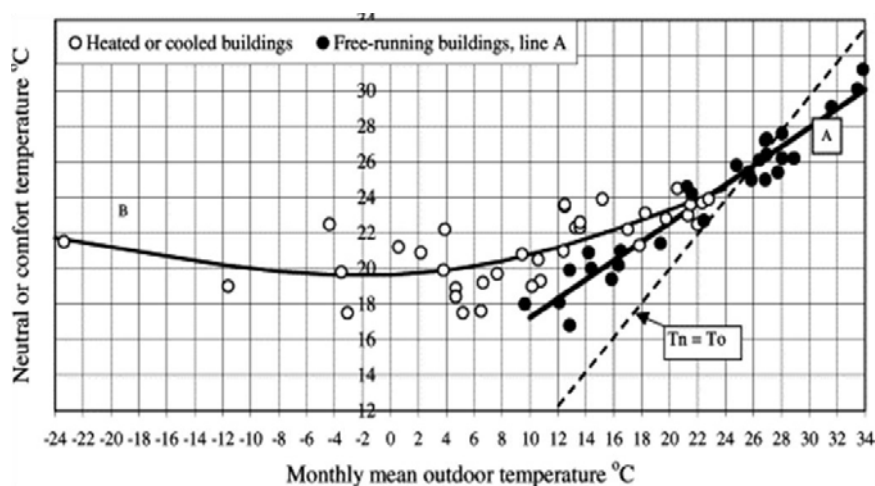

Fig. 3.2.2 Neutral temperature vs. outdoor temperature for active and passive (free-running) buildings (from Nicol cited in Emmanuel 2005).

Fig. 3.2.2 shows the neutral temperature as a function of the monthly mean outdoor temperature for active (heated and/or cooled) and passive (free-running) buildings. The perceived thermal sensation in the active buildings does not seem to depend on the outdoor temperature. The neutral temperature in passive buildings is however closely related to the

outdoor temperature. Nicol & Humphries (2002) found the equation of this relationship to be:

$$T_n = 13.5 + 0.31 \cdot T_{out} \tag{3.4}$$

where

- T_n = the neutral (comfort) temperature (°C)
- T_{out} = the outdoor temperature (°C)

Several studies of the same kind have been conducted in various countries. Fig. 3.2.3 shows results from studies in Pakistan (two studies) and Tunisia. It can be seen that the slope of the line varies from study to study. This is because cultural and behavioural aspects vary from place to place.

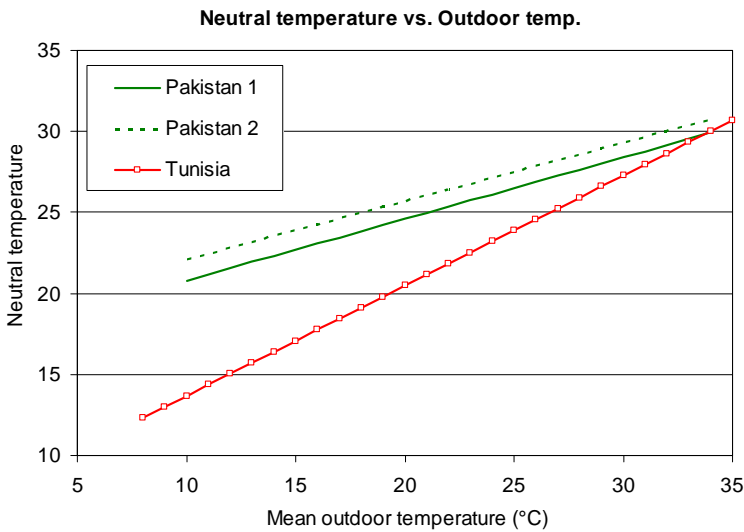

Fig. 3.2.3 Neutral temperature vs. outdoor temperature for two sites in Pakistan and one in Tunisia (Nicol and Roaf 1996, Bouden and Ghrab 2005).

Based on studies from 160 buildings located in North America, Europe, Central Asia, South-east Asia and Australia, ASHRAE has developed an adaptive standard (de Dear and Brager 2002). The study resulted in the following relationship between the neutral and the outdoor temperature:

$$T_n = 17.8 + 0.31 \cdot T_{out} \text{ (°C)} \tag{3.5}$$

The comfort zone is defined as a range above and below this line (eq. 3.5), see Fig. 3.2.4. In this figure the comfort zones of 80% and 90% satisfied are shown.

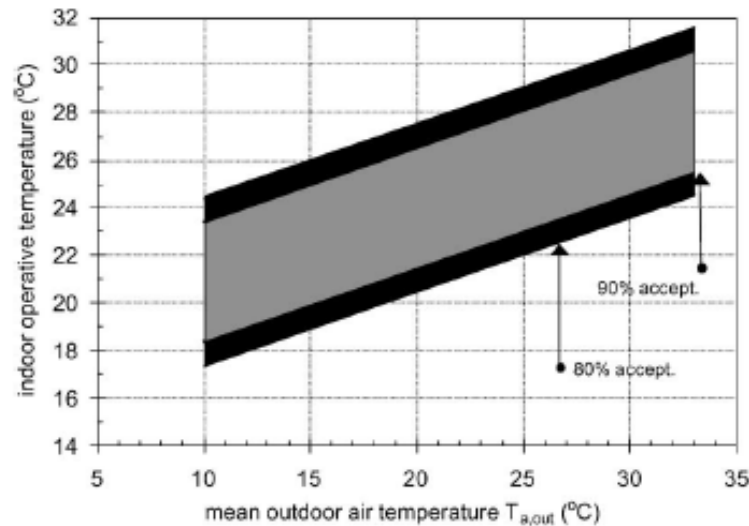

Fig. 3.2.4 Adaptive thermal comfort standard according to ASHRAE showing the comfort zones for 80% and 90% acceptance (de Dear and Brager 2002, ASHRAE 2004).

PMV was recently extended to better predict indoor comfort in naturally ventilated buildings in warm climates by including an expectancy factor (Fanger and Toftum 2002). The new index is called PMV_e and is calculated as:

$$PMV_e = e \times PMV \quad (3.6)$$

where

e = expectancy factor

Table 3.2.6 Expectancy factors for the PMV index

No. of air-conditioned buildings	Expectancy factor e
Many	0.9–1.0
Some	0.7–0.9
Few	0.5–0.7

Source: Fanger and Toftum, 2002

The expectancy factor e , depends on how common air-conditioned buildings are; the more common air-conditioned buildings are, the higher the expectancy factor, as can be seen in Table 3.2.6.

3.2.6 Proposed comfort zones for Jordan

As explained above, the comfort zone will be different depending on if a building is actively climatized (heated and cooled) or if it is passive (free-running, naturally ventilated). In the former case the comfort zone will be

less sensitive to outdoor climate variations whereas in the latter case the comfort zone will vary over the year as a function of the outdoor climate.

Active buildings

For active buildings it is suggested to use the ASHRAE comfort standard 55. This standard, which has proven to function well in several climates worldwide, has different comfort zones for summer and winter because of seasonal differences in clothing and ventilation. As mentioned above, the comfortable operative temperature ranges at 50% relative humidity are 20–23.5°C for the winter and 23–26°C for the summer. However, since the summers in Jordan are hot and dry, the summer range could probably be extended to 23.5–27°C (assuming 30% relative humidity).

The advantage of a higher upper limit (27°C) during summer is twofold:

1. Less energy will be needed for air-conditioning
2. The thermal shock when entering or leaving a cooled building will be less

Passive buildings

To determine the comfort zone for passive buildings the ideal would have been to conduct a field study in order to achieve a relationship similar to those of Fig. 3.2.3. However, such field studies have to cover all seasons of the year and should be conducted in different parts of the country.

In the absence of field study results it is proposed to use the universal adaptive comfort standard developed by ASHRAE and described above (see, de Dear and Brager 2002). Adopting this standard would result in the comfort zones shown in Table 3.2.7 for some Jordanian cities. It has been assumed that 80% of the people perceive thermal comfort within the given ranges.

Table 3.2.7 Comfort zones (80% acceptance) for some Jordanian cities according to ASHRAE adaptive standard

City	Comfort zone (operative temperature, °C)			
	January	April	July	October
Amman	17 – 24	19.5 – 26.5	22.5 – 29.5	20.5 – 27.5
Aqaba	19 – 26	21.5 – 28.5	24.5 – 31.5	22.5 – 29.5
Irbid	17 – 24	19.5 – 26.5	22 – 29	20.5 – 27.5
Ghor Safi	19.5 – 26.5	22 – 29	25 – 32	23 – 30
Guriat	17 – 24	20.5 – 27.5	24 – 31	21 – 28

3.3 Urban microclimate and outdoor thermal comfort

3.3.1 Urban climate on different scales

When countryside air flows over a city, different horizontal layers of air are formed, each of which develops its own climate. According to Oke (2004), three climate scales apply in urban areas: the micro, local and meso scales (Fig. 3.3.1). The micro-scale includes buildings, streets, squares, gardens, trees, etc. The local scale represents urban neighbourhoods, whereas the meso-scale represents an entire city.

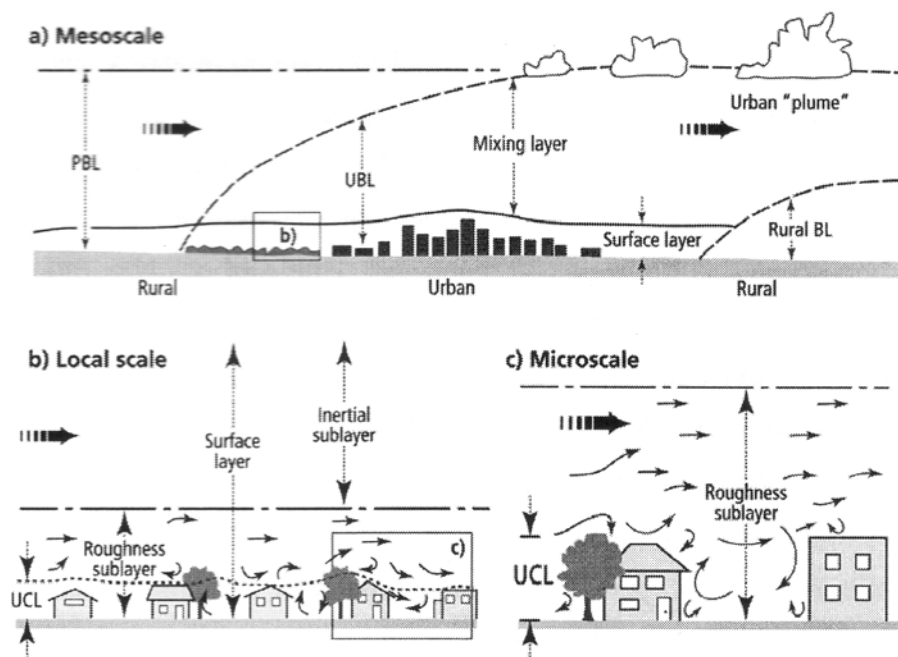

Fig. 3.3.1 Climatic scales in urban areas: meso, local and micro-scale. Modified after Oke (2004) in Johansson (2006).

Vertically, the micro-scale falls within the roughness sub-layer, the height above which micro-climate effects from the buildings and objects below are phased out. The area between the ground and the rooftops is called the *urban canopy layer* (UCL). This layer, which constitutes the lower part of the roughness sub-layer, comprises buildings and the areas around them, such as gardens, streets, squares and parks. Within the UCL, the microclimate is site-specific and varies greatly within short distances.

3.3.2 Factors influencing the urban microclimate

Urban geometry and properties of surface materials

The geometric form of the urban canopy layer and the thermal properties of surface materials greatly influence the urban climate. Built-up areas influence the absorption and reflection of solar radiation, the ability to store heat, and the absorption and emittance of long-wave radiation. Urban geometry is often represented by the urban street canyon (Fig. 3.3.2), which consists of a street aligned with buildings on both sides. The ratio between the height of the buildings and the distance between them is called the height-to-width (H/W) ratio. For asymmetric canyons with varying building heights, the H/W ratio is calculated using the average building height. The reflectivity (albedo) of surfaces, determining the amount of absorbed short-wave radiation, depends mainly on the colour of the surface and varies greatly in urban areas: between about 0.3 for light colours up to about 0.9 for dark colours. Conversely, the ability to emit and absorb heat (long-wave radiation) is very similar for rural and urban surface materials; most emissivity values lie around 0.9.

Anthropogenic heat

All cities release heat from space heating, air conditioning, motor traffic and other domestic and industrial activities that require energy. However this heat is low compared to the radiation energy flux in urban areas.

Air pollution

Air pollution from motor vehicles and industrial activities adds to the aerosols in the air. Consequently, incoming solar radiation is attenuated and its diffuse component increased. The reduction of global solar radiation may vary between 10% and 20%. Thus the ground is heated less when the atmosphere is polluted than for a clear atmosphere. On the other hand, the net outgoing long-wave radiation (the cooling of the ground), is also less for a polluted than for clear atmosphere. The net effect of air pollution on the temperature is therefore small.

Green areas and vegetation

In urban areas, bare and vegetated soils are largely replaced by hard and often waterproof surfaces. Consequently, much of the ground's ability to release energy through evaporation and transpiration is lost. However, green areas within cities act similarly to rural areas and are normally cooler than built-up areas, especially at night. Irrigated green areas can be considerably cooler than their surroundings, even during daytime, especially in semi-arid and arid areas.

Single trees and small clusters of trees can be effective in providing shade. The shading of solar radiation – including direct, diffuse and

reflected radiation (from the walls and the street) – will keep urban surfaces cooler, thus decreasing air temperature.

3.3.3 Influence of the built environment on urban climate

Short and long-wave radiation

The amount of absorbed solar radiation in an urban area depends both on the reflectivities of the urban surfaces and on the canyon geometry.

The direct-beam irradiation on a surface depends on its orientation and on the azimuth and altitude angles of the sun. The amount of diffuse irradiation received at street level depends on the sky view factor (SVF), which expresses the portion of the sky seen from the street, as illustrated in Fig. 3.3.2. The diffuse radiation decreases with decreasing sky view factor.

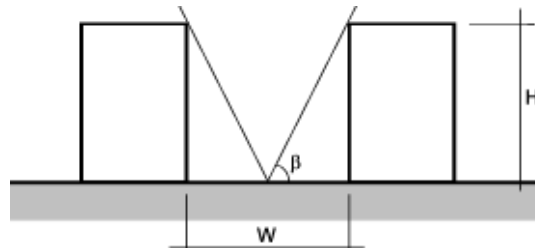

Fig. 3.3.2 Height-to-width ratio (H/W) and sky view factor (SVF) of an urban street canyon. The SVF expresses the amount of the sky seen from the street. For a point in the middle of the street of an infinitely long canyon, $SVF = \cos\beta$.

The overall reflectivity of the urban fabric is generally lower than for rural surfaces. This is because the irregular urban surface tends to trap solar radiation. Due to multiple reflections within the canyons, the amount reflected back to the atmosphere is small.

During the day the incoming solar (short-wave) radiation increases the surface and air temperatures. At night the surface is cooled due to the net outgoing long-wave radiation. This outgoing long-wave radiation diminishes with lower SVF (higher H/W ratio). The more narrow a street is (low SVF), the less heat gain during the day, and less heat loss at night.

Air temperature

The best known characteristic of the urban climate is that cities are warmer than their rural surroundings. The urban *heat island* is primarily a nocturnal phenomenon. The difference between urban and rural daytime temperature is normally smaller, see Fig. 3.3.3.

Field studies in numerous cities, mainly in temperate climates, have shown that the magnitude of nocturnal heat islands increases with increasing H/W ratio (reduced SVF) of street canyons. In the day the urban canyon is a good absorber of solar energy and due to the relatively high thermal capacity of urban surface materials, this energy is stored in

the fabric and not released until after sunset. The largest urban-rural temperature difference occurs on calm and cloudless nights. Under such conditions, nocturnal heat islands of up to 12°C have been recorded.

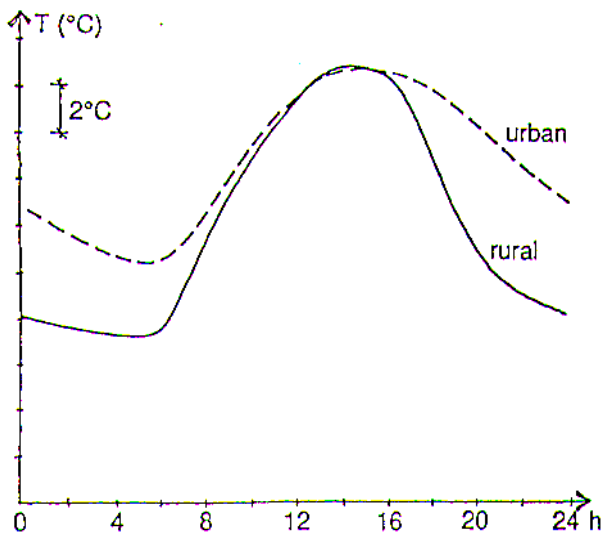

Fig. 3.3.3 Temporal variations of air temperature in an urban area and its rural surroundings (after Oke 1987).

In the day, both heat and cool islands can be found. Daytime heat islands are normally believed to be caused by anthropogenic heat, whereas cool islands are attributed to the shade cast by buildings.

The impact of anthropogenic heat on air temperature is often small and seldom a major cause of urban warming, except in some cities where extensive space heating or cooling is common and buildings are poorly insulated.

Air pollution reduces both net incoming short-wave radiation and net outgoing long-wave radiation and consequently the net effect on the radiation budget is small. This explains why air pollution has a surprisingly limited effect on air temperature (Oke 1987, Arnfield 2003).

Green areas and vegetation can have a significant impact on air temperature. Larger parks are cooler than built-up areas. A temperature difference of 1–2°C is common but can reach as much as 5°C.

In arid regions, irrigated green areas may be considerably cooler than built-up areas due to the so-called oasis effect (Oke 1987). If there is an excess of water, evaporation from vegetation and moist soil becomes so strong that energy is taken from the air, causing it to cool. However if the irrigation ceases, the effect will eventually disappear.

For single trees and small clusters of trees, the effect of evaporation on air temperature is marginal.

Humidity

In general, the urban–rural humidity differences are small. However, there is a tendency for cities to be slightly more humid at night and dryer in the day than their rural surroundings (Oke 1987).

Wind

The complex geometrical forms of urban areas comprising of buildings with sharp edges, strongly affect the regional winds blowing through and over a city. Field measurements and wind tunnel tests have shown that regional horizontal wind speed is reduced to 25–50%. However, wind pattern is highly irregular and characterised by a high level of gustiness. Local wind speeds in urban areas can exceed those of the rural surroundings, especially in the presence of high-rise buildings (Oke 1987).

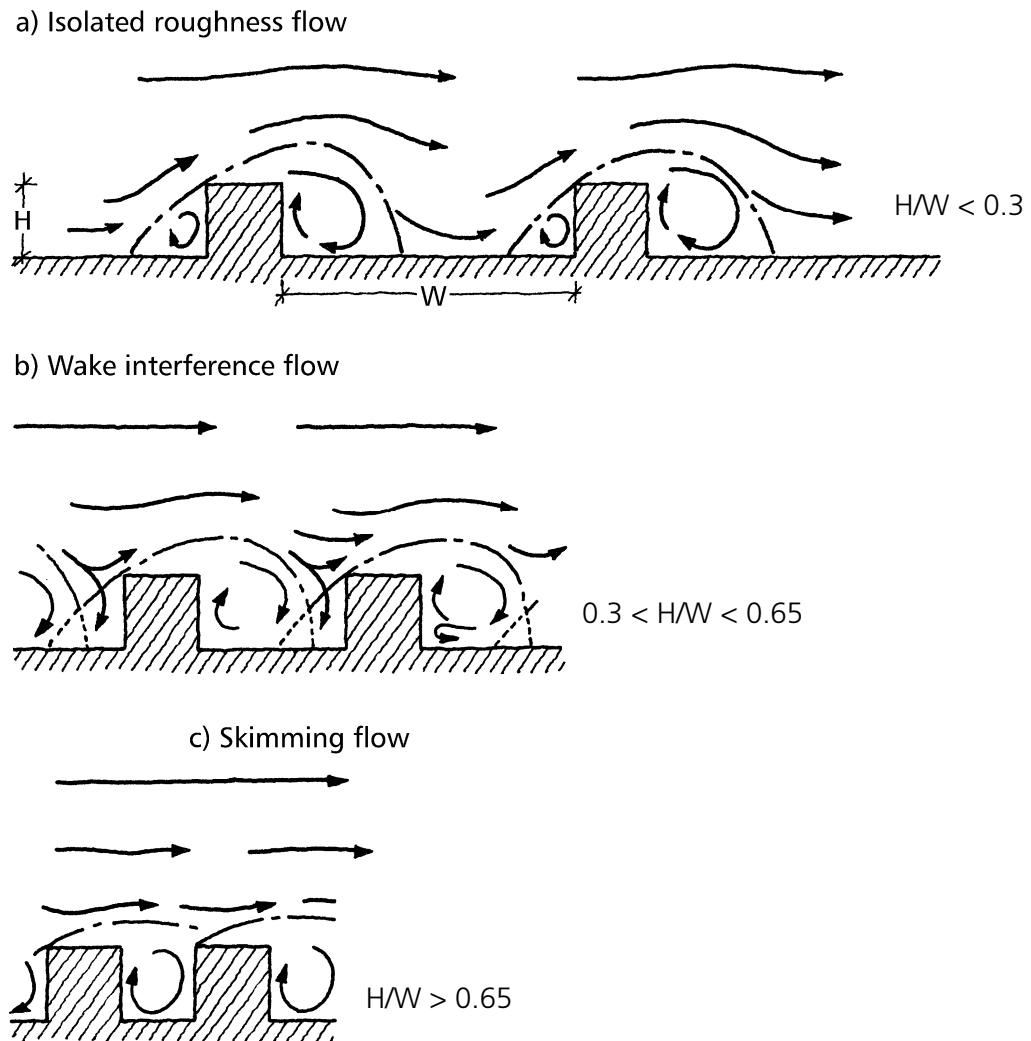

Fig. 3.3.4 Air flow in street canyons with different H/W ratios. The closer the buildings, the more the air flow tends to skim over them. (After Oke 1987)

Using wind tunnel tests and field measurements, some basic wind phenomena have been observed (Oke 1987). For several parallel and symmetrical urban canyons, the wind flow perpendicular to the long-axis of the canyon will depend on the H/W ratio according to Fig. 3.3.4. For $H/W < 0.3$, most of the wind flow enters the canyon. For $H/W > 0.65$, a stable circulatory vortex develops within the canyon and the coupling with the air above the canyon becomes weaker, causing most of the flow to

skim over the buildings. The coupling between the canyon and the air above it thereby decreases with increasing H/W ratio.

The wind patterns may be more complex for irregular urban forms and for wind directions other than perpendicular. For wind flows parallel to an urban canyon, wind speeds may be increased due to channelling (Oke 1987).

3.3.4 Outdoor thermal comfort

Compared to indoor environments (see Section 3.2), outdoor conditions show large temporal and spatial variations and the thermal balance of the body is seldom in a steady state. It is well known that mental and physical performance deteriorates when it is too warm and that at very high temperatures, heat stress may lead to heat-related illness (McIntyre 1980).

Fig. 3.3.5 A person in a street canyon exposed to direct (S), diffuse (D) and reflected (R) short-wave radiation as well as long-wave radiation from the sky (L_{\downarrow}) and the urban surfaces (walls, L_w and street, L_{st}). (Johansson 2006)

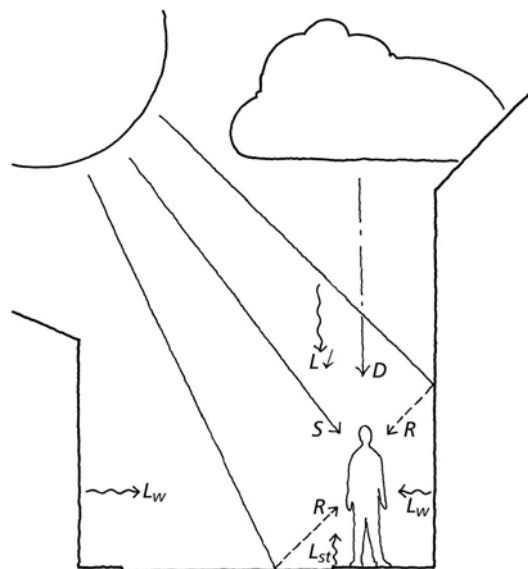

It is very complicated to determine the outdoor mean radiant temperature (MRT – see Section 3.2) due to the extensive variation in radiation from different sources (Fig. 3.3.5). The human body may receive solar radiation as direct and diffuse, as well as reflected radiation from building façades and the ground. Moreover, the body exchanges long-wave radiation with the sky, urban surfaces and with objects such as trees. The magnitude of the radiation from the different sources varies greatly in space and time. The most accurate way to determine the outdoor MRT is by measuring the short and long-wave radiation from different directions. However, MRT can also be estimated through calculations.

Winds change speed and direction rapidly outdoors and a high degree of turbulence makes the wind speed feel higher than the measured mean value.

The level of activity tends to vary more outdoors than indoors, typically from sitting to fast walking. Outdoors, people dress according to seasonal

climate variations. Moreover, people adapt physically to an environment by adjusting how they dress and move, e.g. slow walking when it is warm and faster walking when it is cold.

Psychological factors (see Section 3.2) are likely to be greater outdoors where the environment is much more complex and dynamic. Several studies have shown that the comfort zone was wider outdoors than indoors (see e.g. Nikolopoulou and Steemers 2003, Spagnolo and de Dear 2003). One explanation is that people's expectations are different outdoors because the thermal environment varies much more in time and space and it cannot be controlled.

Another factor that has proven to influence thermal sensation is thermal history, i.e. the climate a person has recently been exposed to. For example, a person who has been exposed to extreme heat for a long time and moves to a shady location will experience a different thermal sensation than someone who has spent a long period of time in the shady environment.

4 Testing as support for energy efficiency in buildings

4.1 Measurement review and advice for the future

4.1.1 Existing twin test rooms

The RSS has constructed two rooms to be used to test the different types of windows available on the Jordanian market (see Fig. 4.1.1). The advantage with these rooms is that they have the full dimension of a normal room resulting in that the heat transfer and convection are representative for a full scale room. This gives the possibility to do realistic long-term monitoring of the performance of a typical Jordan building. An interesting analysis is to compare the air temperature and operative temperature in a full scale room with stone walls or to investigate the occurrence of air stratification under different conditions.

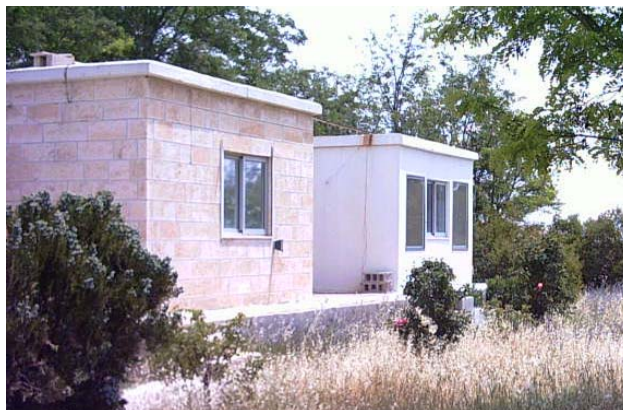

Fig. 4.1.1 The twin test rooms constructed by RSS to test different types of windows

One of the uses of the test rooms is to measure the heat demand for a longer time period keeping the room temperature constant by using electric heaters inside the room. The measuring equipment then needs to be supplemented with electronic electric power meters with a counter interface connected to a PC so the continuous heat demand could be monitored. It is more complicated to measure the required power for cooling during the summertime, since then a cooling system has to be installed and the cooling power has to be recorded.

The two test rooms could be used for testing the impact of windows and sun shades. However, the rooms have a very large thermal mass. This makes it difficult to relate transmission properties of the window systems to temperatures because of the long time lag. The thermal mass from the un-insulated floor is especially large and a way to reduce this influence is, e.g. to cover the floor with a thick layer of polystyrene foam protected by a simple floorboard. Some kind of insulation in the ceiling could reduce the large influence from the sun on the total heat flow. However, even with these measures, the flows through the windows will be comparatively small and the difference between the two tested window systems will be harder to evaluate accurately.

A prerequisite for being able to compare the two rooms is that they must be thermally identical. This includes window openings and the colour of the façades and roof.

4.1.2 Integrating sphere for determining direct solar transmission

Important solar heat data for a window is the direct transmittance τ and the total solar energy transmittance g^2 . Optical data such as transmittance and reflectance for components like solar shading devices, can be used in calculation and simulation programs such as ParaSol together with the window properties to obtain the total g-values and the energy (heating and cooling) demands for the combination of glazing and solar shading. Transmittance is a more general quantity than g-value because it is a value which is representative for the component, independent of what window system it is incorporated in. With optical techniques, performance data of a test sample can be obtained relatively quickly as the thermal mass is not involved. Detailed measurement of the transmittance variation with the angle of incidence can be made with relatively little effort.

An integrating sphere intended for the conditions in Jordan for the testing of direct transmission on transparent building components is suggested (see Fig. 4.1.2). For places where access to the sun from a clear sky is irregular, it is necessary to use an artificial light source. It is difficult to find a light source with nearly parallel light and a proper spectrum. In Jordan where access to a clear sky is available most days of the year, the integrating sphere can take advantage of the real sun as a light source.

² The g-value represents the total solar energy transmittance through a window including both the fraction of solar radiation that enters directly through the window and the fraction of inwardly flowing solar energy absorbed in the window compared to the total solar insolation. Values range from 0 to 1.

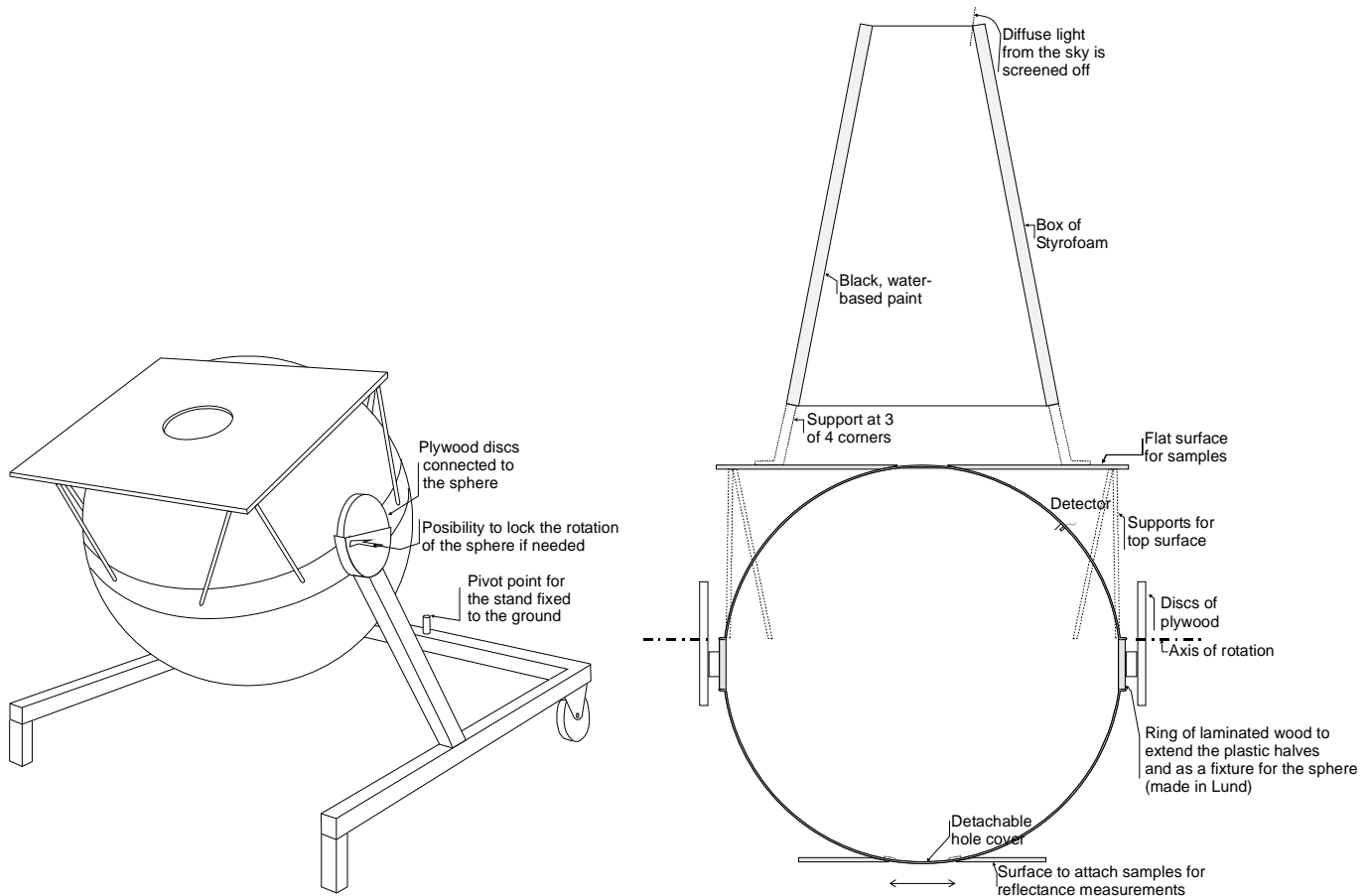

Fig. 4.1.2 The sphere is mounted on the stand without the shading box (left) and the shading box (right) that reduces the diffuse light from the sky.

4.1.3 Calorimetric measurements of total transmission for windows and shadings

An important characteristic of a window-sunshade system is the total transmission of the solar radiation that also includes the secondary transmission from the absorbed heat in the window system. This is called the g-value which gives a direct measure of the heat load from the solar irradiation on a complete window system.

In Lund, we have taken the measurements of the g-value using two identical boxes. The boxes are kept at room temperature and the cooling/heating and a number of temperatures are monitored. We have found that using one of the two twin boxes as the reference to be very valuable. The two boxes are measured under identical climate conditions and an accurate comparison can be made of, for instance, with or without solar shading. We suggest the type of twin boxes shown in Fig. 4.1.3 for the conditions and demand in Jordan, which has a passive cooling system with heat exchangers to the outside air using water as a carrier for the heat. Thus problems with controlling the temperature and an expensive cooling unit are avoided. The heat enters the boxes as irradiation, or heat

to the air from the secondary transmission. The collector inside the box is, if possible, designed to be able to absorb both. This can be achieved by covering the inside area close to the window system with a tailor made, air to water heat exchanger and painted black and also agitate the air around the inside fins of the heat exchanger. The suggested boxes are made small in volume to keep costs down and also to reduce the thermal mass, which is important for accuracy, as the temperature is not actively kept constant. Very light materials must be used, like a sandwich construction of Styrofoam, and compensation for stored heat due to thermal capacity must be made.

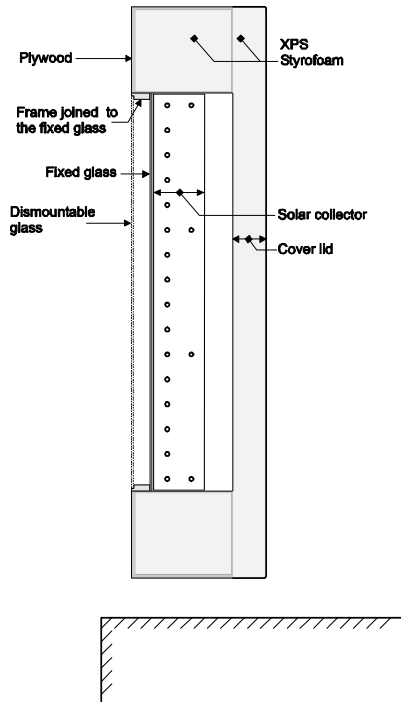

Fig. 4.1.3 The proposed flat calorimetric boxes for the testing of g-values.

Another reason to make the boxes small is that they can then be tilted easily. In that case the façade can get the incidence angle at noon for a south facing window system for the whole year, independent of the testing time of year.

A test period with a large variation in solar intensity is not suitable when testing passive heating/cooling principles. Measurement taken on a cloudless day for several hours before noon is recommended. However in Amman such suitable sun conditions for measurements are frequent.

The suggested boxes can accommodate only one size of windows, but this limitation also offers an easy set up procedure and optimal measuring conditions.

Other equipment required includes accurate flow meters and a pyranometer to register the irradiation perpendicular to the front wall. Also needed are circulation pumps and a logger to record data.

4.1.4 Calorimetric measurements of total transmission for totally opaque shadings – A simple method

Based on the experiences from the measurements of g -values on shadings made in the solar simulator in Lund, a simple method using a heat flow meter is suggested.

A component with a reasonably well defined heat resistance is made from a piece of 10 mm polystyrene foam sandwiched between two thin glass panes. The temperature difference between the two glass panes is measured at several points with a thermopile. A schematic outline of how the thermopile is made is shown in Fig. 4.1.4 (right). The copper-constantan thermocouple wires are soldered to small pieces of circuit board to maintain a good constant thermal contact to the glass panes. The air is agitated on the back side of the heat flow measuring plate to compensate for the extra heat resistance from polystyrene foam, and makes the temperature distribution closer to that of a one pane window.

A pyranometer measures the irradiation. A logger with low level inputs is used for the measurements.

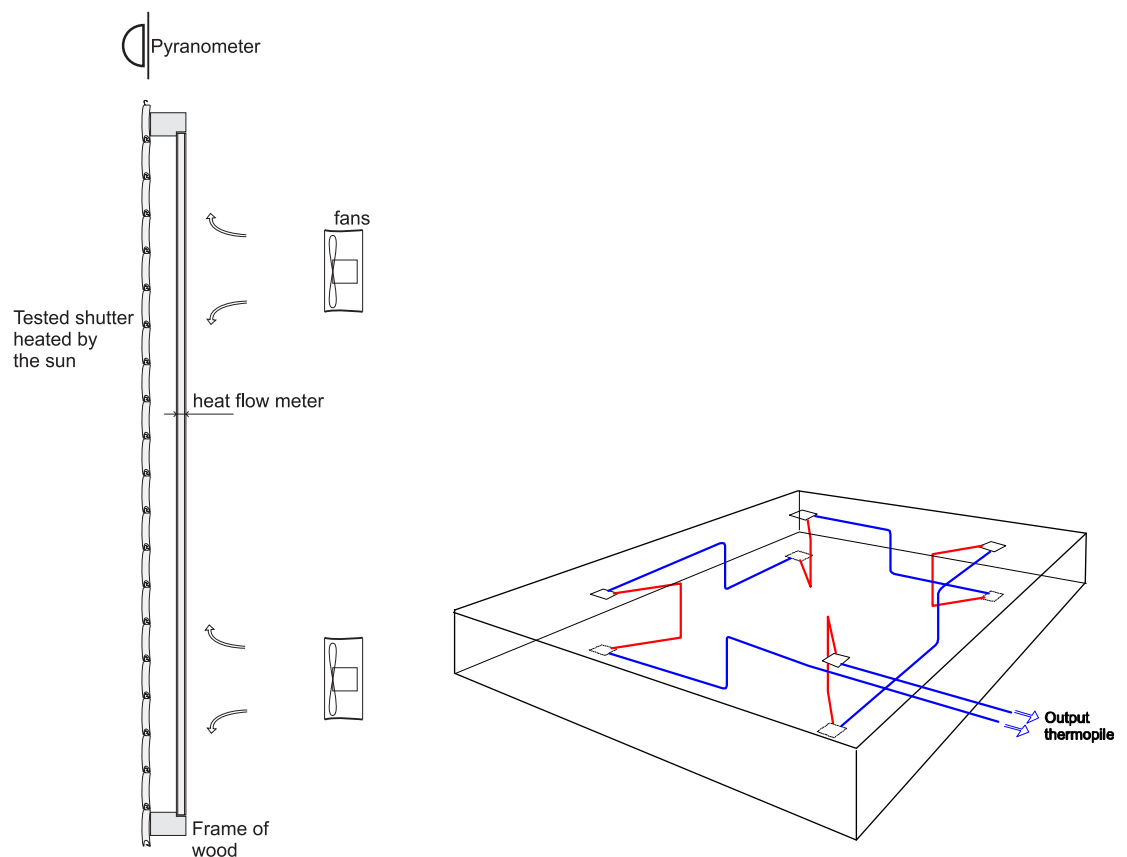

Fig. 4.1.4 Setup of a g -value measurement of an opaque shutter using a heat flow meter (left) and a schematic layout of a thermopile with four pairs of thermocouples (right).

4.1.5 Supplementing the existing hot-box for U-value measurements on window systems

The U-value of the glass of an ordinary window is well known and rather easy to calculate if the glass and gas properties are known. The U-value of the frame is however more difficult to calculate due to the converging heat flow along the perimeter of the glazing and through the frame itself. In particular, frames constructed of thermally un-broken aluminium can create very large thermal bridges. Testing the U-value of the whole window (including glass, frame and a possible box for roller blinds) is thus crucial to emphasise the importance of the whole window construction and its influences on thermal losses.

A facility for dedicated testing of U-values for windows would thus be a valuable resource. With a few modifications, the existing hot-box can be utilised. A flexible setup is desired so that it is easy to change between the testing of windows and whole wall ordinary tests.

In order to perform standardised measurements of the U-values for windows, the surface temperatures opposite the window and the air temperatures need to be measured. It is assumed that the present guarded box can be used.

A section of a partition wall for window testing is shown in Fig. 4.1.5.

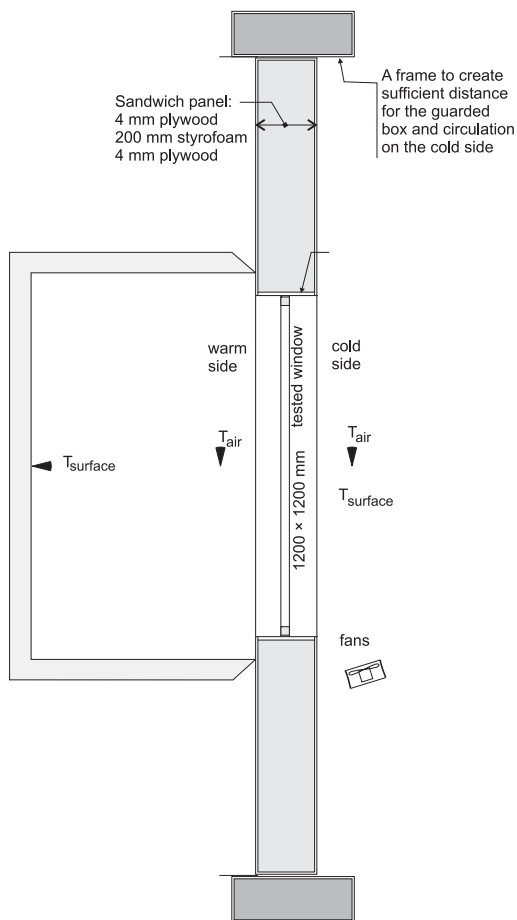

Fig. 4.1.5 The proposed arrangement for U-value measurements on windows as a compliment to the existing hot-box.

A specially made partition wall with an opening for the window has to be constructed. A suitable construction is a sandwich construction with a thick cellular plastic core surrounded by very thin pieces of plywood. The recess surfaces around the hole are also to be made with thin plywood to reduce thermal bridges. High precision of the surfaces facilitates the exchange of tested windows and to ensure the connection between guarded box and wall is airtight.

A new logger and multiplexer to monitor temperatures and count pulses from a meter for electric energy is needed. The multiplexer together with the reference temperature terminal could be permanently connected to the measuring points of the hot box setup, whereas the logger could be made easily detachable with a few flexible connectors and used for other temporary purposes.

Supplementary surface temperatures of the warm and cold side opposite of the window need to be collected, as well as the air temperatures.

A few 12 V DC fans blowing on the cold side of the window could provide the increased convective transfer to simulate outdoor conditions. DC fans have the advantage of simple control by varying the voltage.

4.1.6 System for the testing of solar collectors (Low priority)

Jordan has very good conditions for using solar thermal systems to heat water for domestic use. The most cost effective system is one with natural circulation with the storage tank outdoors above the collector. A system with natural circulation and with vacuum tubes as solar collectors directly connected to the tank has recently been developed in China. The basic principle is shown in Fig. 4.1.6. It is therefore interesting to compare the performance of these systems based on natural circulation heated by conventional flat plate collectors alternatively heated with vacuum tubes.

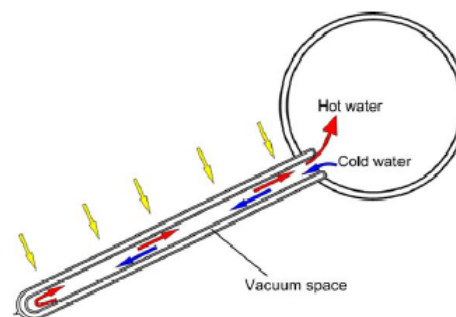

Fig. 4.1.6 Schematic drawing of a water-in-glass evacuated tube solar collector.

Two to four systems for parallel monitoring of a solar thermal system with natural circulation is constructed.

The performance for a thermo-siphon (natural circulation) type of solar collector system can be measured in a standardised way by drawing off the daily production of hot water after the sun heating phase.

Drawing off a measured quantity of water after the collector has produced the daily amount standardises the way of measuring the performance of a thermo-siphon (natural convection) type of solar heated hot water system. In Fig. 4.1.7 the essentials of such a measuring system is shown. The irradiance on the collector and the ambient temperature should be monitored by a logger. A logger is also used for controlling an automatic scheme for drawing off water from the storage tank.

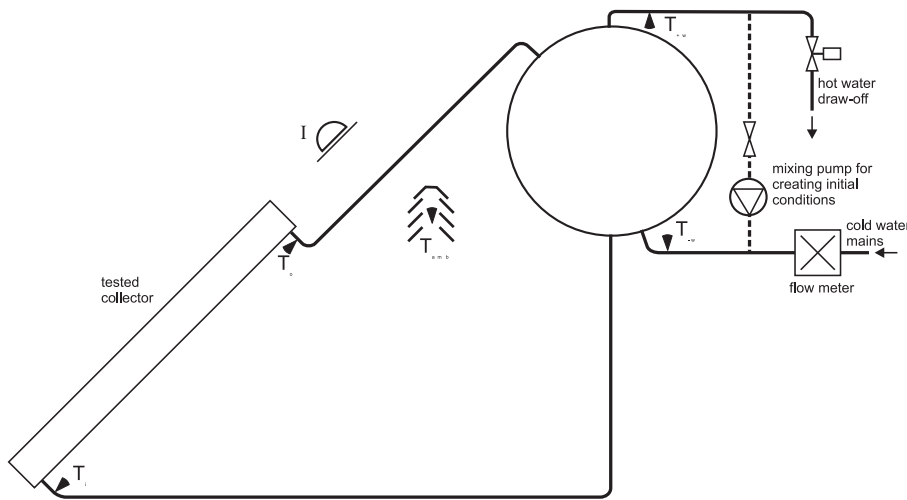

Fig. 4.1.7 Experimental set-up for the testing of a thermo-siphon type of domestic hot water system.

For systems with separate pipes for hot and cold water from the collectors, the inlet and outlet temperatures can also be measured.

If the charging process during the daytime will be studied, the vertical temperature profile in the tank also needs to be monitored.

The first tests are performed in parallel for comparing the performance of systems with flat plate collectors versus vacuum tube collectors.

4.1.7 Testing of a large system with flat plate collectors (Low priority)

Large collector systems are suitable to heat water in multi-family houses, hotels, institutions and industries. It is therefore of interest to characterise large systems for use in Jordan.

A relatively large system is installed at the RSS, see Fig. 4.1.8. This system could be connected to the heating and hot water system and monitored. The flow, inlet and outlet temperatures from the collectors, the irradiance and the ambient temperature are then monitored.



Fig. 4.1.8 Photo of the existing large system flat plate collectors at the RSS.

Alternatively, the produced heat can be dissipated to the outside air by means of a water–air heat exchanger during the measurements. In this way, more controlled conditions can be maintained.

4.1.8 Testing of Photo-Voltaic systems (Low priority)

The interest in, and the international market for PV-system is growing very quickly. This could be a motivation for monitoring and testing PV-systems to gain knowledge of how they perform.

PV systems are generally classified into stand-alone and grid connected systems. In the past, stand-alone systems were most common and had a larger commercial market. Today however the number of grid connected system is growing very fast.

The main problem with PV solar power is the high investment cost for the module. The PV-modules are of three different types: single crystal silicon, poly-crystalline silicon and thin film cells. There are expectations that the thin film technique will be able to reduce the cost for the modules.

In order to learn more about these systems and modules, two projects are suggested.

Design, construction and monitoring of a grid connected PV system and a stand alone PV system

A stand alone system, Fig. 4.1.9 (left), and a grid connected system Fig. 4.1.9 (right), are constructed and the performance is monitored over a long

period. This means that the electric output, irradiance and temperature are collected on a data logger.

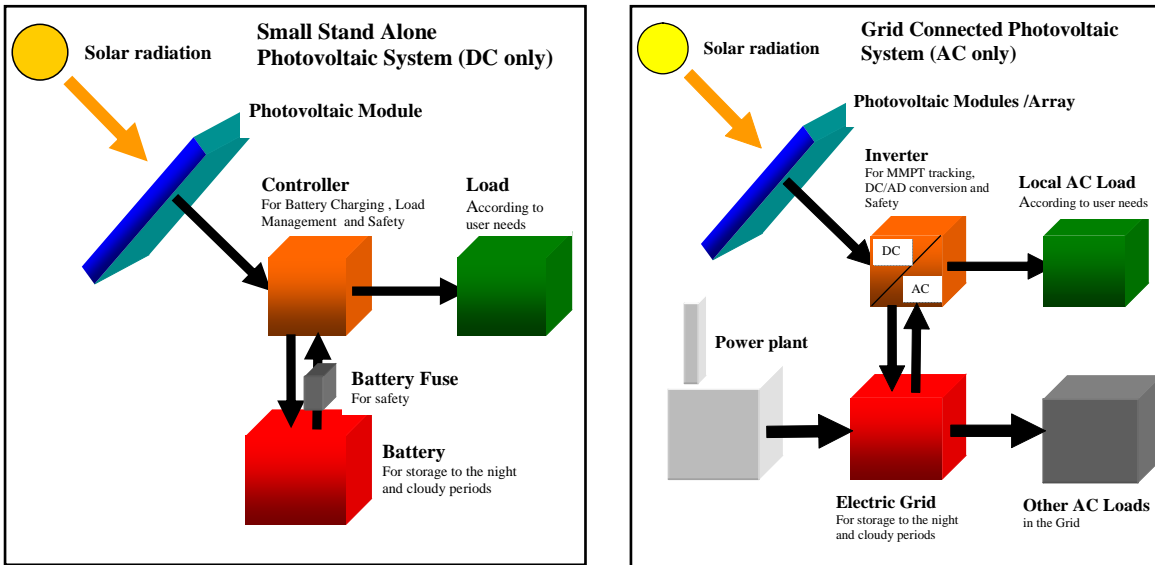

Fig. 4.1.9 Schematic drawings of a stand-alone PV-system (left) and a grid connected PV-system (right).

Long-term testing of PV-modules

The different types of modules are installed on a test site. The irradiance, ambient and module temperatures are monitored. At intervals, the I-V curves of the modules are measured. This means that equipment measuring the I-V curve should be purchased. This equipment includes an I-V curve tracer and instrumentation for the monitoring of irradiance and temperature of module and ambient.

4.2 Measurement of g-values and heat resistances on solar shutters

The thermal performance of four solar shutters available on the Jordanian market was tested in the laboratory of Energy & Building Design, Lund University.

4.2.1 Testing of g-values in a solar simulator

The g-values for the shutters are measured in combination with a double pane window. The panes are 4 mm and of low iron glass. The air gap between the panes is 30 mm. The air gap between the outer pane and the shutter is also 30 mm. The window opening is 1.17×1.17 m. The inner heat transfer coefficient is created by an 8 mm air gap between the inner

pane and the calorimeter plate kept at constant temperature. The mean irradiation is 866 W/m^2 .

The desired outside convective transfer is achieved by a row of fans directed towards the window, below the sight line between the window and the lamps. A high convection on the outer surface gives a favourably low g-value. When testing, it is recommended to have a relatively low convective heat transfer to generate a higher g-value which is closer to the worst case. When testing U-values on the other hand, a high convective heat transfer is normally used.



Fig. 4.2.1. The solar simulator with a mounted white aluminium shutter.

The test period is one and a half hour with perpendicular sunlight in the solar simulator. The heat capacity in the three layers; shutter, outer pane and inner pane in combination with the heat resistances between them created a delay in the heat absorption. Thus the delay for the heat to reach the calorimeter plate could be expected to be long. This is seen in Fig. 4.2.2 where the upper curve is the heat transfer between the panes and the lower curve is the heat absorbed by the calorimeter plate.

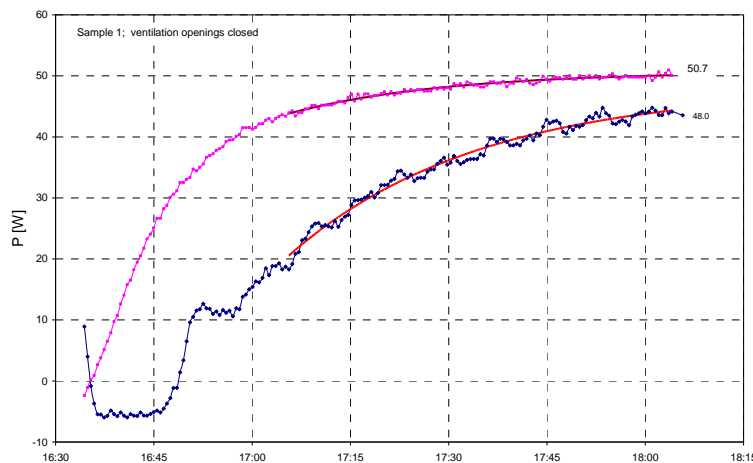

Fig. 4.2.2 Measured heat flow behind a shutter. The upper curve is calculated from temperatures on the window and the lower curve is a calorimeter measurement.

The low g-values for a shutter mean that small levels of energy have to be measured. When measuring such small values, it is hard to attain high relative accuracy with the calorimetric measurements on the solar simulator equipment built for high levels of heat. Instead of using the measured absorbed heat on the calorimeter plate, the heat flow is measured by utilizing the well defined air gap between the panes as a known heat resistance together with the recorded temperatures on the panes. This could be done since the shutter can be assumed to be completely opaque and thus there is no direct transmission, only secondary heat. The heat transfer is calculated according to ISO 15099 standard. The emissivity for the glass used in the calculation is 0.837.

An exponential decline for the last hour is fitted to extrapolate the final value. The final values for the power derived from the pane temperatures differ very little from the power measured calorimetrically.

The g-values in Table 4.2.1 are the ratio between the transferred heat for a window with the sunshade compared to a window without a sunshade. This is denoted as $g_{sunshade}$ in the table.

$$g_{sunshade} = \frac{g_{system}}{g_{window}}$$

The shutters are measured in combination with a 2-pane window. From assumed resistances, an estimation of the g-values for a single pane window can be made. This is shown in the last column in Table 4.2.1.

Table 4.2.1 Measured g-values for shutters related to a two pane window

Sample	Description	Ventilation slots	2-pane g-value $g_{sunshade}$	Estimated 1-pane g-value $g_{sunshade}$
Shutter 1	White aluminium, plastic foam core (Al Mámary)	Open	0.042	0.059
Shutter 1	White aluminium, plastic foam core (Al Mámary)	Closed	0.052	0.073
Shutter 2	Dark aluminium, plastic foam core	Closed	0.137	0.192
Shutter 3	White PVC, no plastic foam core	Closed	0.05	0.07
Shutter 4	Dark PVC, no plastic foam core	Closed	0.1	0.14
Shutter 4	Dark PVC, no plastic foam core	Open at top and bottom	0.059	0.83

4.2.2 Measured heat resistance for shutters measured in a guarded plate apparatus

To obtain an idea of the possible reduction of the U-value when the different shutters are lowered at night to reduce heat loss, thermal measurements of the heat resistances were performed. The method

measures the heat resistance from the internal surface to the external surface of the shutters and calculates the expected U-values in combination with a double pane and a single pane window. In this way an accurate figure of the thermal properties of the shutters as separate units can be found.

Setup

The shutter samples are placed on top of the guarded ring apparatus according to Fig. 4.2.3 and demonstrated in Fig. 4.2.4 and Fig. 4.2.5. The measured area is 0.6×0.6 m and the heated area is 0.8×0.8 m. The used heat flux is 75 W/m^2 . The current and the voltage over the heater are logged continually together with the temperatures in the ambient air and the two shutter surfaces. A photo of the thermocouple measuring point is shown in Fig. 4.2.6. The thermocouple wire is around $\text{Ø } 0.10$ mm thick. The wire is embedded in viscous silicon rubber. A good thermal contact is achieved and the transparent silicon has little optical disturbance. It is important that the same thermocouple is used to measure the outer surface in the solar simulator.

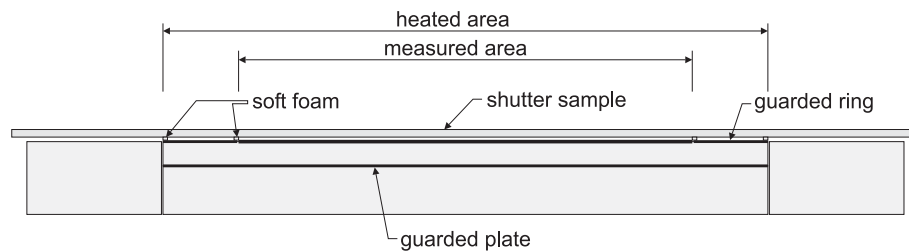

Fig. 4.2.3 Section of the guarded plate/guarded ring apparatus.



Fig. 4.2.4 Setup with a shutter sample in position for measurement.



Fig. 4.2.5 The measuring area and the guarded ring.

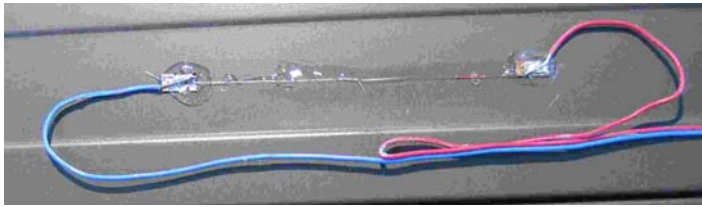

Fig. 4.2.6. Detail of a thin thermocouple used on the front surface of the shutter

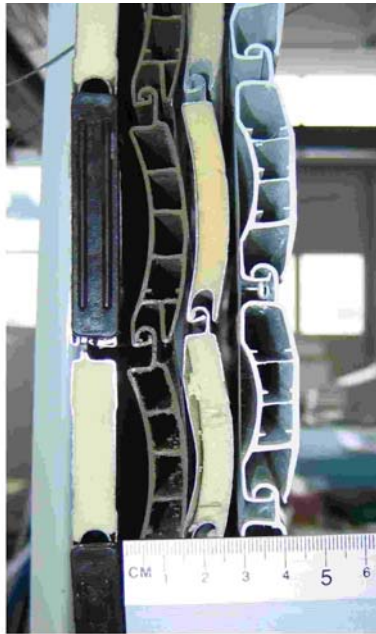

Fig. 4.2.7 Cross section of the profiles used in the shutters. From left to right: Shutter 2; Shutter 4; Shutter 1; Shutter 3.

From the two temperatures over the shutter and the heat flow the heat resistance is calculated.

Results and calculations

The U-values must be regarded as the lowest that can be attained as the air gap behind the shutter can be assumed to have leaks to the outside air in reality, especially in the top box. However a comparison of different types of shutters can be made.

Table 4.2.2 Measured R-values. Also calculated U-values are shown; without shutters and with the shutter as an extra layer

Sample	Description	R_{sample} [K·m ² /W]	Total, 2-pane U-value [W/m ² ·K]	Total, 1-pane U-value [W/m ² ·K]
Shutter 1	White aluminium Plastic foam core	0.029	2.56 → 1.70	4.55 → 2.39
Shutter 2	Dark aluminium Plastic foam core	0.052	2.56 → 1.63	4.55 → 2.26
Shutter 3	White PVC No plastic foam core	0.143	2.56 → 1.42	4.55 → 1.88
Shutter 4	Dark PVC No plastic foam core	0.114	2.56 → 1.48	4.55 → 1.98

As can be seen in Table 4.2.2, the heat resistances (R) of the aluminium shutters are considerably higher than the plastic ones despite having an insulating foam core. This is explained by the fact that the aluminium acts as a thermal bridge due to its high thermal conductivity and the good insulating property of the foam becomes insignificant.

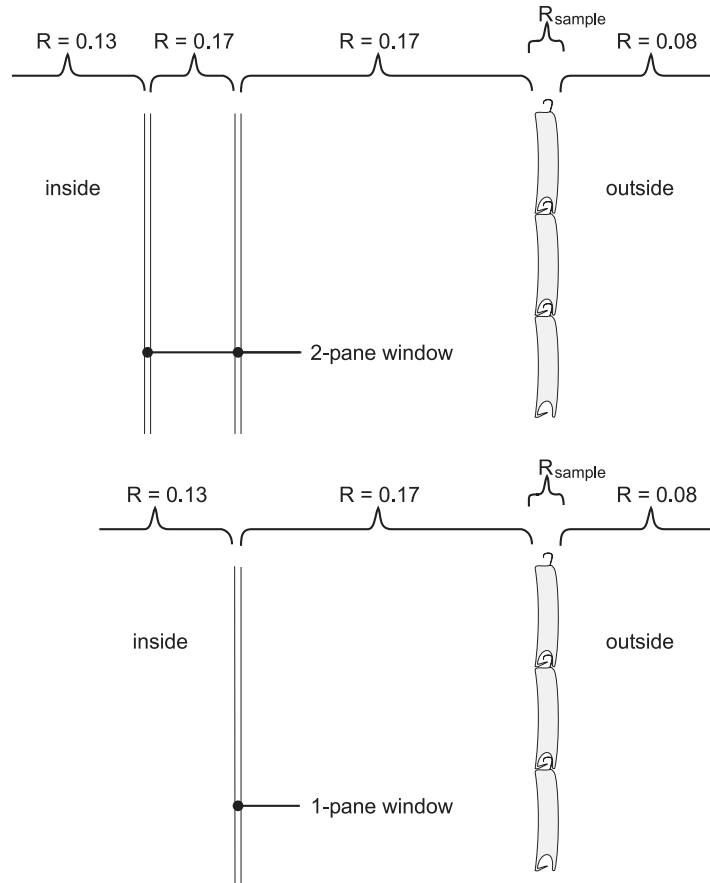

Fig. 4.2.8 The values of heat resistance used in the calculation in Table 4.2.2

4.3 Ventilation measurements

4.3.1 Background

Most apartments in Jordan are naturally ventilated (Blomsterberg 2008). Natural ventilation is achieved by opening windows. It is also very common for apartment buildings to have a ventilation shaft in the middle of the building. This shaft is as high as the building and serves as a passive stack. There are openings between the bathroom and the shaft.

There is likely to be natural ventilation (air infiltration) even when the windows are closed. The facade construction is often masonry, which

means that most air leakage paths are related to leaky windows. There are air leakage paths e.g. between the window frame and the facade.

Ventilation heat losses can constitute an important part of the overall energy losses. Information on ventilation rates is needed when calculating the energy use of a building. For an apartment with natural ventilation it is difficult to calculate the ventilation rate. In Jordan there is very little knowledge on the actual ventilation rate of apartments. Therefore the ventilation rate was measured in a typical apartment.

4.3.2 Method

The ventilation performance is measured using a special kind of passive tracer gas technique, the “homogenous emission technique” (Stymne 2006). Miniature passive tracer gas sources (capillary tracer gas sources with emission adjustment device) are distributed within the building to be measured, in such a way that the emission rate of tracer gas is proportional to the room volumes in all parts of the building. This means that the local tracer gas concentration in a given room will tell how long the air in that room, on average, has spent in the building. The inverted value of the local mean age of air is equivalent to the commonly used ventilation quantity “the local air change rate” (ach)³.

In this study, passive sampling is collected using charcoal adsorption tubes. The sampling tubes are distributed and left in the building for approximately three weeks. The passive samplers are later analysed in a laboratory.

The advantages of this method are that the averages of local mean ages can be obtained and that the collection of the measurements does not interfere or disturb the occupants. Information can also be obtained on how the ventilating air is distributed within the building.

A typical apartment in Amman is measured. The apartment is located on the first floor of a four storey building. The floor area is approximately 160 m² and there are three bedrooms, one living room, one dining/reception room and two bathrooms (see Fig. 4.3.1).

The occupants are asked to fill in an airing questionnaire to describe when the windows are open and closed.

Weather data is measured at Amman airport.

³ The number of air changes per hour (ach) indicates how many times the entire air quantity in a room is renewed within one hour.

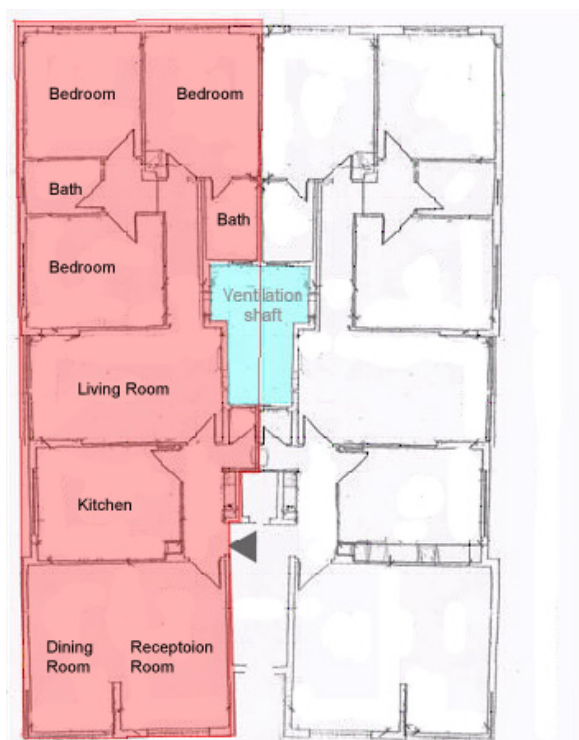

Fig. 4.3.1 Floor plan of the tested apartment (left hand side)

4.3.3 Results

The average measured ventilation rate during the winter period is $0.31 \text{ ach} \pm 13\%$. The ventilation rates are similar in the individual rooms (see Table 4.3.1). The ventilation rates are fairly low. This is due to the fairly small average temperature difference between the inside and outside, (7 K – indoor average $+ 18.4 \text{ }^\circ\text{C}$ and outdoor average $+ 11.2 \text{ }^\circ\text{C}$), the low wind speed (2.7 m/s), and the fact that the windows are closed most of the time (apart from morning airing). Many building codes recommend a minimum ventilation rate of 0.5 ach .

Table 4.3.1 Measured ventilation rate in the tested apartment in Amman, 14 Feb. – 07 March 2007

Room	Room specific air flow rate, ach
1 Dining room	0.31 ± 0.03
2 Kitchen	0.32 ± 0.03
3 Living room	0.33 ± 0.03
4 Bedroom	0.30 ± 0.03
5 Hallway	0.29 ± 0.03
7 Bedroom	0.36 ± 0.03
8 Bedroom	0.28 ± 0.03
Total ventilation flow rate	135 ± 133
Specific air flow rate	$0.31 \pm 13 \%$

The average measured ventilation rate during the summer period is 2.38 ach \pm 13%. The ventilation rates are similar in the individual rooms (see Table 4.3.2). The ventilation rates are high. This is due to the fact that many windows are half opened during the day and night. The driving forces for the ventilation are rather small. The average temperature difference between inside and outside is 2 K (indoors average + 26.4 °C and outdoors average + 24.4 °C), and the wind speed is 2.7 m/s.

Table 4.3.2 Measured ventilation rate in the tested apartment in Amman, 30 Aug. – 17 Sep. 2007

<i>Room</i>	<i>Room specific air flow rate, ach</i>
1 Dining room	2.57 \pm 0.03
2 Kitchen	2.26 \pm 0.03
3 Living room	2.58 \pm 0.03
4 Bedroom	2.26 \pm 0.03
5 Hallway	2.13 \pm 0.03
7 Bedroom	2.26 \pm 0.03
8 Bedroom	2.29 \pm 0.03
Total ventilation flow rate	1010 \pm 133
Specific air flow rate	2.38 \pm 13%

5 Software development as support for energy efficiency of buildings

5.1 Background

The objective of the project *Defining Means and Criteria for Improving Thermal performance and Minimising Energy Consumption in Buildings in Jordan* was to introduce new climatic considerations and concepts to the Jordanian construction industry in order to develop local methods and techniques for the design and construction of buildings in an environmentally sustainable way. It was decided to use some design tools to simulate and evaluate the different designs of constructions. However two of the design tools to be used, DEROB-LTH and ParaSol, needed further development and an adaptation to fulfil the requirements in the project. A brief description of the two design tools and the further developments carried out is given below.

5.2 DEROB-LTH

DEROB-LTH, an acronym for Dynamic Energy Response of Buildings, originates from the University of Texas. It is a design tool with the possibilities of exploring the complex dynamic behaviour of buildings for different designs and is used for commercial, research and educational purposes. The tool is under continuous development at the division of Energy & Building Design at Lund University. The form of the building can be modelled in a flexible way with a number of 3D surface geometries, from triangles to five-sided polygons. The number of zones is maximized to 8. Libraries for opaque and transparent materials and constructions are included and can be modified according to special needs. The program has a semi-transparent building element type that can be used for modelling a shading screen, e.g. an awning. The calculations, based on an energy balance model, use a time interval of one hour and calculate the different types of building energy performance parameters in response to the hourly values of climatic data, scheduled input for indoor temperatures, maximum power for heating and cooling, internal loads, airflow rates and window openings.

Building energy performance is given by the following hourly results:

- Heating and cooling loads (W)
- Energy use for heating and cooling (kWh)

- Indoor temperatures (°C)
- Temperatures for all surfaces facing outdoors (°C)
- Temperatures for all inner surfaces facing a zone (°C)
- The operative temperature for a zone (°C)
- Air inflow and outflow for forced and natural ventilation and leakage (l/s)
- Solar irradiation on the outer transparent surfaces of a zone (Wh)
- Solar irradiation transmitted into a zone (Wh)
- Solar insolation absorbed into a zone (Wh)
- Thermal comfort indices: Predicted Mean Vote (PMV), the Predicted Percentage of Dissatisfied (PPD) according to the international Standard ISO 7730 (ISO, 1994)

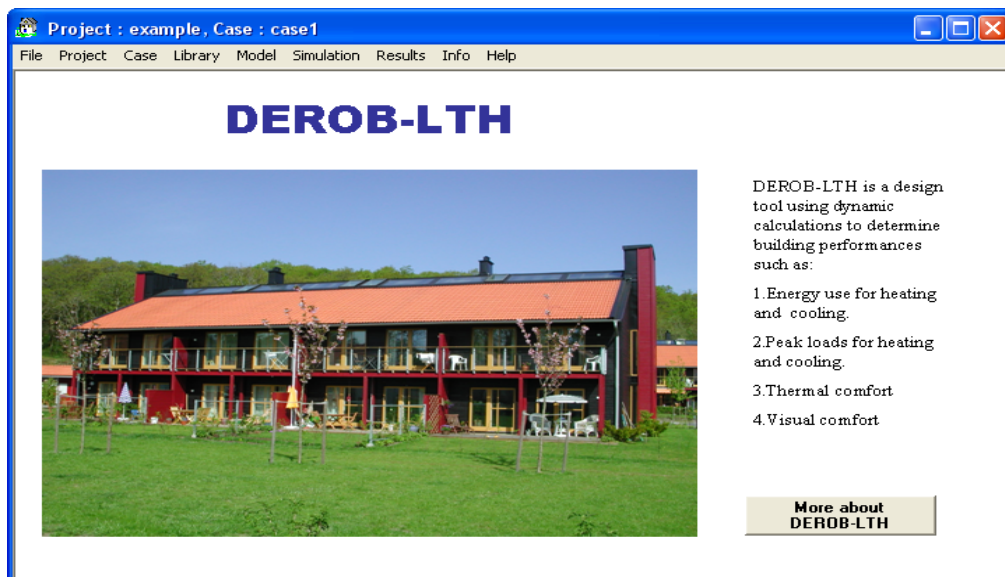

Fig.5.2.1 The DEROB-LTH main window.

Previous research projects have placed new demands on the calculations in the DEROB-LTH program. They are:

1. Thermal Model of Windows (Källblad, 1998b).
This model uses one node for each pane and treats the non-linear heat transfer between the panes in a detailed way using the first principles of physics. The absorption of solar radiation in each pane is also calculated with incident angle and all reflections between panes etc. taken into account.
2. Shading of Diffuse Radiation (Källblad, 1998a).
An accurate method for calculating the shading of short wave and long wave radiation is developed. Calculation of view factors is of great importance in order to determine diffuse radiation on the outer surfaces.
3. The Comfort Program (Källblad, 1998c).
A post-processor is developed. The purpose of the program is to

graphically illustrate the distribution of the Predicted Mean Vote (PMV), the Predicted Percentage of Dissatisfied (PPD) according to the international Standard ISO 7730 and the operative temperatures in a room.

The DEROB-LTH main window is shown in Fig.5.2.1. The main new features implemented as part of this project are described below.

5.2.1 DEROB-LTH adaptation

HVAC model

A new model (Hellström, 2007) for the ventilation of the building has been developed. Ventilation now includes mechanical ventilation, infiltration, leakages through opened windows and between internal volumes e.g. through a door, staircase.

Wind data

To fully use the new HVAC model, wind data should now be included in the climatic data file of a site. The model also takes the type of terrain into account. There are four different options.

HVAC schedule

The HVAC schedule has been further developed. It is now possible to control the indoor climate in a more detailed way. The hourly assignment of values has been fully detailed and is now also based on monthly periods. Some new parameters for the HVAC model have been added to the HVAC schedule.

5.2.2 Other new features

Daylight calculations

The same post-processor for daylight calculations used in the ParaSol program has been added (Bülow-Hübe, 2001). The distribution of the illumination on a defined surface in a room is presented in a diagram. A diagram can illustrate each hour throughout the period of the simulation. The level of the surface can be varied. The geometry of the studied room is limited to be a right-angled parallelepiped. An example of such a diagram is shown in Fig. 5.2.2.

Interior curtains

The interior curtains can now be identified by a unique name.

Results

The following results from a simulation are added to the output list of Excel tables:

- Airflows calculated in the new HVAC model
- Monthly results for energy loads and temperatures

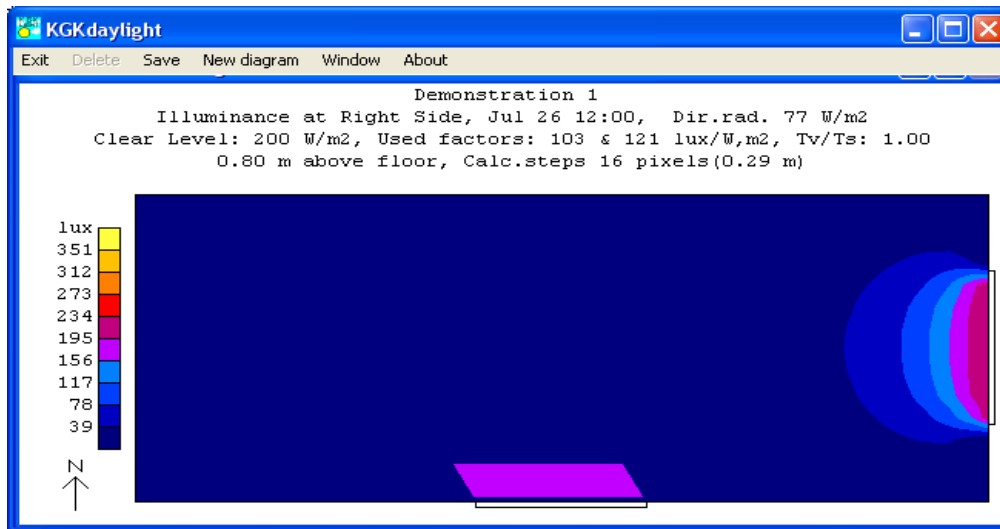

Fig. 5.2.2 A diagram for illumination on a horizontal surface in a room.

Error handling

The error handling function has been enhanced to take care of different types of errors in a more user friendly way.

Help function

The printed user's manual has been replaced by a help function accessible from all parts of the user interface.

5.3 ParaSol

ParaSol is a design tool to study the potential of solar protection for the different types of sunshades and glazing systems and their influence on building energy performance at an early design stage. ParaSol performs hourly dynamic energy simulations and is based on the calculation engine in the DEROB-LTH program. It provides monthly results for the total and direct solar energy transmittance (g - and T - values) of the sunshade and the combination of sunshade and window system and calculates their influence on the building energy performance. The program has post-processors for studies of daylight and thermal comfort. The user can select between external, interpane and internal sunshades. Within each such group, a number of different geometries and material properties can be selected.

A simple geometric model, which can symbolize a rectangular office module, is predefined. All dimensions can be changed and the building rotated. ParaSol is mainly intended for the simulations of buildings such

as offices, schools and hospitals, but rooms in residential buildings can also be simulated.

Building energy performance is given by the following results:

- a) Monthly mean values for solar transmittance:
 - Total transmittance (g) for the window and window/sunshade system
 - Direct transmittance (T) for the window and window/sunshade system
- a) Energy balance:
 - Max. heating and cooling load with/without sunshade (W)
 - Total heating and cooling demand with/without sunshade (kWh)
 - Daily heating and cooling demand with/without sunshade (Wh/Day)
 - Duration diagram for hourly heating and cooling demand with/without sunshade (Wh/h)
 - Duration diagram for the indoor temperature of the zone ($^{\circ}\text{C}$)
 - Duration diagram for the operating temperature in the zone ($^{\circ}\text{C}$)
 - Daily sum of solar insolation into the zone with/without sunshade (Wh/Day)
 - Peak loads during the design day for heating and cooling (W)

The ParaSol main window is shown in Fig.5.3.1. The main new features implemented as part of this project are described below.

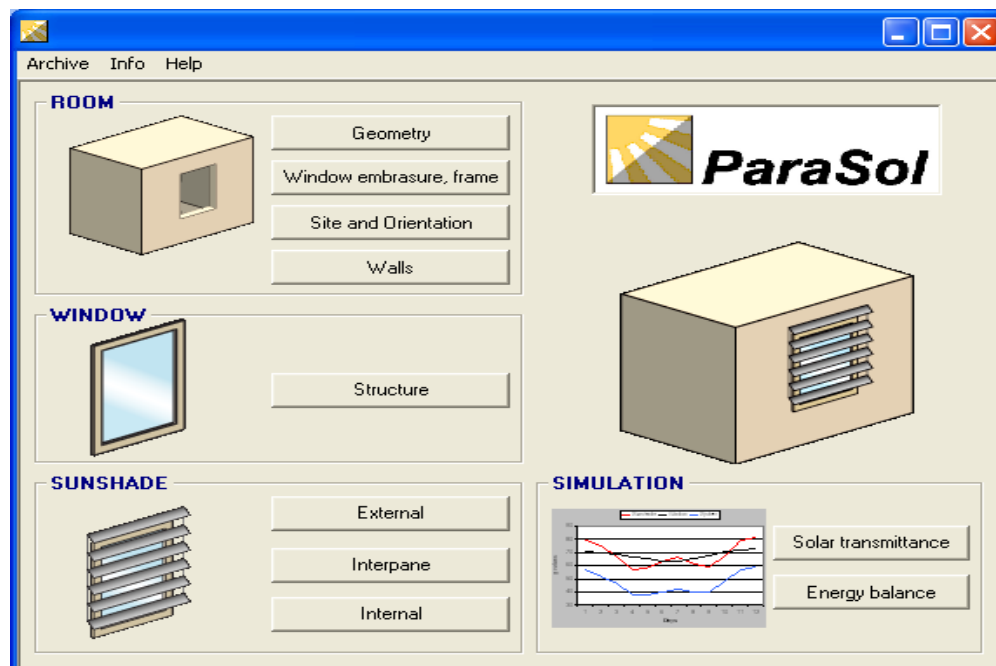

Fig.5.3.1 The ParaSol main window.

5.3.1 ParaSol adaptation

External sunshade

A new type of external sunshade, shutter, is modelled and included in the entry for external sunshades in ParaSol. The material thickness and the heat conductivity for the shutter can be varied, as well as the width of the air gap to the outer glass pane. This air gap can be selected to be naturally ventilated (by thermal forces), setting the opening width of the top and bottom of the sunshade. A schematic picture of the shutter is shown in Fig.5.3.2.



Fig.5.3.2 A schematic picture of a shutter, the new type of external sunshade.

External wall

The geometric model of ParaSol includes internal walls and one external wall. For the external wall the U -value can be varied. To support the range of Jordanian wall constructions the upper limit for possible U -values is increased to $1.5 \text{ W/m}^2\text{K}$.

6 Towards a climate conscious design in Jordan

Buildings constructed in the last decades in Jordan are not well adapted to the climate; consequently more energy is consumed for heating and cooling. Even though the actual use of air conditioning systems is more limited to administrative buildings, hotels and wealthy residences, the energy consumption will increase whilst the thermal comfort for the majority of the population will get worse because of high energy prices.

The objective of this chapter is to promote a more climate-conscious design at both building and urban level and to suggest improvements of the current building and urban codes.

The aim of thermal regulations is to improve the energy efficiency of buildings, principally for heating and cooling, whilst ensuring an acceptable level of thermal comfort. Section 6.1 presents a survey of some existing energy codes.

Section 6.2 presents a proposal for climatic zoning of Jordan based on two methods: the classical degree day method for heating and cooling and an alternative method using computer simulations of thermal performance of a typified apartment to verify and adjust the climatic zoning.

In Section 6.3 computer simulations are used for a parametric optimisation of the different elements of construction, based on a typical new middle income apartment in the city of Amman.

In Section 6.4 the urban microclimate in Amman is analysed using computer simulations and measures to improve the human comfort of pedestrians are proposed.

6.1 Survey of existing energy codes

A literature review of existing energy codes from different parts of the world from both cold and warm climates was carried out (Johansson, 2008). The aim was to cover codes mainly from countries similar to Jordan in terms of climate and construction techniques, e.g. the Middle East and North Africa; however codes from temperate climates were also included. The review concerns both residential and commercial buildings. Commercial and public buildings account for a considerable amount of energy use, but the residential sector is equally important due to its size. The review concentrates on regulatory measures related to the design of the building, i.e. the thermal performance and air tightness of the building envelope. This is because most heat losses are through the building envelope, especially in poorly insulated buildings.

6.1.1 Characteristics of the studied energy codes

The energy codes from the countries listed in Table 6.1.1 were studied. These energy codes apply to either residential or commercial and public buildings, or both. The major difference between these categories is that the former is used day and night, the latter only during office hours (except for hotels).

Table 6.1.1 Energy codes studied and the type of buildings they apply to

Country	Residential buildings	Commercial buildings
Algeria	Yes	No
Dubai/United Arab Emirates	Yes ¹	Yes ¹
France	Yes	Yes
Hong Kong	No	Yes
India	Yes ²	Yes
Jordan	Yes ³	Yes ³
Malaysia	No	Yes
Singapore	Yes	Yes
Sweden	Yes	Yes
United Kingdom	Yes	Yes
USA	Yes	Yes

¹Only air-conditioned buildings

²Only multifamily buildings above three storeys

³Only air-conditioned buildings above 100 m²

The number of climate zones varies greatly from country to country. The number of climate zones was not always reflected by the size of the country. E.g., the whole continent of India has five climate zones, France, with an area of 540 000 km² has three climate zones, whereas Lebanon (10 000 km²) has five climate zones, see Table 6.1.2.

Table 6.1.2 Number of climate zones in some of the countries studied

Country	No. of zones
Algeria	4 (8*)
France	3
India	5
Lebanon	5
Malaysia	1
Sweden	1
United Kingdom	1
USA	19

*Including sub-zones

Building energy codes can be either prescriptive, i.e. putting requirements on the different building elements in a building, or performance-based, i.e. putting requirements on the thermal performance of the whole building –

or a combination of both. The regulatory approach varies greatly between the studied countries. Many of the codes allow several methods including both prescriptive and performance-based approaches. Table 6.1.3 shows the regulatory approach of the countries in this survey.

Table 6.1.3 Regulatory approach of the countries in the survey

<i>Country</i>	<i>Approach</i>
Algeria	Prescriptive/Performance
Dubai/United Arab Emirates	Prescriptive
France	Performance
Hong Kong	Prescriptive
India	Prescriptive/Performance
Malaysia	Prescriptive
Singapore	Prescriptive
Sweden	Performance
United Kingdom	Prescriptive/Performance
USA	Performance

Table 6.1.4 The approach of thermal insulation requirements of the countries in the survey

	<i>Thermal insulation requirements</i>			
	<i>Roof</i>	<i>External walls</i>	<i>Ground floor</i>	<i>Whole envelope</i>
Algeria	No	No	No	Yes
France	No	No	No	Yes
Hong Kong	Yes	Yes	No	No
India	Yes*	Yes*	No	Yes*
Jordan	Yes	Yes	No	No
Lebanon (proposal)	Yes	Yes	Yes	No
Malaysia	Yes	Yes	No	No
Singapore	Yes	Yes	No	No
Sweden	No	No	No	Yes
United Kingdom	Yes*	Yes*	Yes*	Yes*
USA, general	Yes*	Yes*	Yes*	Yes*

**Either each building element or whole envelope.*

6.1.2 Comparison of thermal insulation requirements

The codes with a prescriptive approach have requirements on the thermal insulation of different building elements whereas the codes with a performance-based approach put the requirement on the building envelope as a whole. In the latter approach – sometimes referred to as the building envelope trade-off method – the thermal performance of the

entire building envelope should be less than a certain value or standard design. This gives the flexibility to compensate a poor insulation in one part of the building with better insulation in other parts. Several of the codes combine individual requirements on each building element with a requirement on the whole envelope. A few codes (France, Sweden since 2007 and India (optional) have requirements on the total performance of the building which means that the estimated annual energy use has to be less than a certain value. Such a method allows trade-off between envelope insulation and efficient equipment for heating and cooling. The insulation requirements of the countries of this survey are shown in Table 6.1.4.

In general the requirements on the thermal insulation of building elements concern maximum values for the thermal transmittance (U). The U-value of a building element is calculated as:

$$U = 1/R \tag{6.1}$$

$$R = \sum_{i=1}^n R_i + R_{si} + R_{se} \tag{6.2}$$

where R_i = the thermal resistance of each layer i in the building element [W/ m²°C]
 R_{si} = the interior surface resistance [W/m²°C]
 R_{se} = the exterior surface resistance [W/m²°C]

Examples of typical values for R_{si} and R_{se} are given in Johansson (2008).

When determining the U-value of the whole building, parts of the construction with poor insulation must also be included in the calculation, for example, thermal bridges in the concrete beams junctions between walls and floors. The average thermal insulation of the building envelope, U_{env} , is most commonly calculated as:

$$U_{env} = \frac{\sum_{i=1}^n (U_i \cdot A_i) + \sum_{j=1}^m (k_j \cdot L_j)}{\sum_{i=1}^n A_i} \tag{6.3}$$

where U_i = thermal transmittance of element i [W/m²°C]
 A_i = area of element i [m²]
 n = number of building elements in the envelope
 k_j = thermal transmittance of thermal bridge j [W/m²°C]
 L_j = length of thermal bridge j [m]
 m = number of thermal bridges

A comparison of the requirements on U-values for different building elements is shown in Table 6.1.5. The requirements on roofs are higher than for walls in all of the studied codes, where there are also

requirements on the ground floor, except in Dubai and India. In all of the codes the requirements on thermal insulation increase as the climate gets colder, except in the case of India where the warm-humid climate zone has higher requirements than the cold climate zone.

Table 6.1.5 Maximum requirements on thermal transmittance (U-value) of different building elements for different countries

	Climate zone	Heating degree days	Maximum U-value			
			Roof	Wall	Window	Ground floor
Dubai, 2003	–	–	0.44	0.57	2.1–3.3	–
France, 1991 (recommended values)	H1	2 700	0.25	0.60	2.25	0.40
	H2	2 200	0.25	0.60	2.45	0.40
	H3	1 500	0.25	0.60	2.45	0.45
India, 2006*	Composite	–	0.26/0.41	0.35/0.35	3.2	–
	Hot dry	–	0.26/0.41	0.37/0.35	3.2	–
	Warm hum.	–	0.26/0.41	0.35/0.35	3.2	–
	Temperate	–	0.41/0.41	0.43/0.40	6.9	–
	Cold	–	0.26/0.41	0.37/0.35	4.1	–
Jordan, 1990**		–	1.0/2.7	1.8/2.7	3.5/6.7	1.0/2.7
Jordan, 2008			1.2	1.6	3.4/5.7	0.8/1.2
Lebanon, 1998 (proposal)	H1	3 500	0.45	0.85	2.60	0.45
	H2	2 500	0.60	1.00	2.60	0.60
	H3	2 000	0.70	1.10	2.60	0.70
	H4	1 300	0.85	1.25	2.60	0.85
	H5	700	0.95	1.35	2.60	0.95
Sweden (before 1992)	I+II	–	0.17	0.25	2.00	0.20
	III+IV	–	0.20	0.30	2.00	0.25
United Kingdom, 1995***	–	–	0.2-0.25	0.45	3.0-3.3	0.35–0.45
USA, IECC, 1999****	17	5000–7200	0.15	0.26	1.48	0.77–0.55
	14-16	3600–5000	0.15	0.30	1.59	1.02–0.77
	13	3300–3600	0.15	0.33	1.70	1.09–1.02
	10-12	2500–3300	0.17-0.15	0.33	1.70	1.16–1.09
	9	2200–2500	0.20-0.17	0.36	2.33	1.16
	8	1900–2200	0.20	0.36	2.33	1.16
	6-7	1400–1900	0.20	0.43	2.50	1.16
	2-5	400–1400	0.25-0.20	0.48	2.67	–
1	<400	0.28-0.25	0.48	4.20	–	

*Values for roof and wall regard buildings aimed for 24 hour and daytime use, respectively

** Values for roof, wall and floor regard space conditioned buildings >100 m² and non-conditioned buildings <100 m², respectively

***The lower and higher values concern SAP ratings below and above 60, respectively

****Values for the floor are calculated from required R-values without taking the soil resistance into account

6.1.3 Thermal requirements for the summer

The following codes have requirements on thermal performance, or recommendations for improved thermal comfort in warm season: Algeria, Dubai, France, Hong Kong, Lebanon, Malaysia and Singapore and USA. The code in Algeria, which concerns residential, public and commercial buildings, requires a very detailed calculation on the heat gain through

the building envelope including both opaque building elements and glazed areas. The total heat gain must be lower than a reference value. In Dubai and India the requirement for windows concerns both maximum U-values and maximum solar heat gain coefficient (shading coefficient). In Hong Kong, Malaysia and Singapore the requirement is on the overall thermal transmission of walls – a value including U-value and the solar heat gain coefficient (shading coefficient) of windows.

6.1.4 Requirements on thermal inertia

There are no requirements on thermal mass in the studied codes. However, in France the thermal mass is taken into account in more advanced calculations. In Lebanon a high thermal mass is suggested for buildings in the warmest climate zones. Where thermal insulation is applied, this should be positioned on the outer part of the building element in order to take advantage of the thermal mass.

6.1.5 Requirements on air tightness

The French code allows an air permeability⁴, at a pressure difference of 1 Pa, of 0.3 to 2.0 m³/h/m² for windows and doors, whereas opaque walls should have 0.5 m³/h/m². In India the maximum air leakage allowed for entrance doors and revolving doors is 5.0 l/s,m². The maximum air leakage for other types of fenestration and doors is 2.0 l/s,m². In Sweden the requirement on air tightness of the building envelope is 0.8 l/(s m²) for a pressure difference of 50 kPa between outdoors and indoors.

6.1.6 Minimum requirement for ventilation

Several codes have minimum requirements on ventilation for health reasons. In France the requirement is 25 m³/h for a normal apartment. In Sweden the ventilation for the building should be at least 0.35 l/(s m²) which correspond to 0.5 air changes per hour. In the USA a minimum number of air changes per hour of 0.35 is recommended.

6.1.7 Concluding remarks

The survey has covered both prescriptive and performance-based energy codes. The former approach may limit architectural freedom but has less requirement on the level of knowledge among designers and builders. The latter allows greater architectural freedom but requires higher knowledge and access to computer tools.

Most of the studied codes have requirements for the cold season. In general the requirements increased with colder climate, both within each country as well as between countries.

⁴ Air permeability is a measure of infiltration (unplanned air changes) measured in m³ of air leakage per m² of external area of the building per hour. It is measured by creating a pressure difference between the outside and inside of the building when all intentional openings and ventilation systems are closed.

Of the studied codes, the ones of Algeria, Dubai, France, India, Lebanon (proposal) and USA take summer conditions into account. In Algeria a very detailed calculation is done. The other codes have simpler requirements in regard to the solar shading of windows and recommendations for the use of thermal mass. Thermal mass is important during the warm season as heavy walls absorb heat, thereby reducing and delaying the effects of outdoor temperature extremes on the air-conditioning system.

In this literature review the emphasis has been on the thermal performance and air tightness of the building envelope. However, other aspects such as passive techniques, efficiency of equipment for heating and cooling, use of renewable energy such as solar energy are also important. In the future *all* energy-saving measures must be considered.

In general, the studied codes do not take into account passive heating or cooling techniques such as building orientation, passive solar design and thermal mass, even though these aspects also influence the energy use in buildings.

Since Jordan experiences both cold winters and hot summers, the energy code should cover thermal performance for both heating and cooling. The codes must be easy to understand, possible to implement and easy to enforce by the authorities. Since both prescriptive and performance-based codes have their advantages and disadvantages it is recommended to combine both methods. Passive heating or cooling techniques as well as the use of solar energy should be encouraged.

6.2 Climatic zoning of Jordan

The climatic zoning has been done in three steps:

1. Winter and summer climatic zoning based on degree days of heating and cooling respectively.
2. Verification of the two climatic zonings by thermal computer simulation. The thermal behaviour of a model building has been simulated under the influence of the climate of different important cities. A similar thermal behaviour of the model under the influence of the climate of two cities implies that these cities belong to the same climatic zone.
3. Report the climatic zoning in a Table where all cities of Jordan are represented.

6.2.1 The degree day method

Winter climatic zoning

The temperature limit of 18°C is used as a reference in most of the known thermal codes in the world (e.g. France, USA, Algeria, Sweden, Lebanon) and the annual normal values noted as heating degree days are calculated

by adding differences between 18°C and the daily average temperature when it falls below 18°C.

The number of heating degree days is calculated according to the following formula:

$$HDD = (t_i - t_m) \times Nb \tag{6.4}$$

Where: HDD = number of heating degree days.
 t_i = Interior temperature equal to 18°C.
 t_m = Monthly average Temperature.
 Nb = Number of days per month.

Table 6.2.1 Definition of the winter climatic zone for the principal cities

Zone	Criteria	Cities of the zone
Zone 1	HDD > 1000	08 Ramtha 09 Irbid 11 Ras Muneef 12 Amman Univ. Jordan 13 Amman Airport 15 Naur 16 Maadaba 18 Er Rabah 19 El Hassen 20 Shoubak 21 El Qurein 23 Mafrak 25 Wadi Dhuleil 26 Zarka 31 Jafr 32 Ma'an
Zone 2	500 < HDD < 1000	10 Taiyiba 17 Wadi Wala 22 Ruwashe 24 Safawi 27 Azrak N 28 Azrak S
Zone 3	HDD < 500	01 Baqura 02 Shunah 03 Wadi Yabis 04 Deir Alla 05 Ghor Safi 06 Aqaba

From the analysis of data collected from different meteorological stations, Jordan can be divided into three climatic zones, with one sub zone for winter thermal comfort:

Zone 1 includes cities where the number of Heating Degree Days (HDD) is over 1000. It covers high altitudes localities more than 300 metres above sea level and characterised by a cold winter.

Zone 2 includes cities where the number of Heating Degree Days (HDD) is between 500 and 1000. It includes the lowland localities characterised by a continental climate.

Zone 3 includes cities where the number of Heating Degree Days (HDD) is below 500. It includes the southern regions characterised by a mild winter and hot summer.

Table 6.2.1 presents principals cities for every defined climatic zone.

Summer climatic zoning

There are two ways to determine the summer climatic zoning:

1. Using the reference temperature. This is the average temperature which is rarely exceeded over a year, e.g. in France this temperature does not occur for more than 5 days per year. This method allows the design of cooling systems required for extreme climatic situations. (The 5 hottest days are thus ignored, however, these days are however likely to occur during the summer vacation period). The advantage with this method is that it takes extreme summer conditions into account while its weakness is that it does not provide the energy demand for cooling.
2. Using cooling degree days (CDD). This method uses a temperature limit, e.g. 26°C, as a reference, and the cooling degree days are calculated by summing the differences between 26°C and the daily average temperature when it is over 26°C.

The number of Cooling Degree Days is calculated according to the following formula:

$$CDD = (t_m - t_i) \times Nb \quad (6.5)$$

Where: CDD = number of cooling degree days.
 t_i = Interior temperature equal to 26°C.
 t_m = Monthly average Temperature.
 Nb = Number of days per month.

From the analysis of the obtained results, Jordan could be divided into three zones:

Zone A includes the localities where the number of the CDD is above 400, mainly the cities in the Jordan Valley.

Zone B includes the localities where the number of the CDD is below 400 and above 100.

Zone C includes the localities where the number of the CDD is below 100.

Table 6.2.2 presents principals cities for every defined climatic zone.

Combining summer and winter climate zoning

The winter and summer climate zoning based respectively on HDD (Heating Degree Days) and CDD (Cooling Degree Days) shows a possible common division except for the stations of 10 and 17 Taiyibia and Wadi Wala. Zone 1 in the winter climatic zoning correspond to Zone C in the

summer climatic zoning and zone 2 to zone B and zone 3 to zone C respectively.

Table 6.2.2 *Definition of the summer climatic zones for the principal cities*

Zone	Criteria	Cities of the zone
Zone A	CDD > 400	01 Baqura 02 Shunah 03 Wadi Yabis 04 Deir Alla 05 Ghor Safi 06 Aqaba
Zone B	100 < CDD < 400	22 Ruwashe 24 Safawi 27 Azraq N 28 Azraq S
Zone C	CDD < 100	08 Ramtha 09 Irbid 10 Taiyiba 11 Ras-Muneef 12 Amman Univ. Jordan 13 Amman Airport 14 Amman Roman Th. 15 Naur 16 Maadaba 17 Wadi-Wala 18 Er-Rabah 19 El Hassen 20 Shoubak 21 El Qurein 23 Mafraq 25 Wadi Dhuleil 26 Zarka 29 Queen Alia Int. Airp. 31 Jafr 32 Ma'an

6.2.2 Validation of the climatic zoning through computer simulations

Thermal computer simulations were carried out to validate the established climatic zoning. It consisted of the calculation of the heating and cooling loads for a typical model in the different meteorological stations used in the calculations of HDD and CDD.

This step could be considered as the ultimate verification for the climatic zoning. A similar building model is simulated under all the different climatic data of Jordan. The model's reaction under these climates is a synthesis of all the thermal phenomena occurring in the building. A similar result for different climate stations means that these climates' stations belong to the climatic zone.

The model used for the simulation is typical apartment in Amman with an area of 133 m². It is comprised of a living room, a hall, two bedrooms and kitchen. The model is shown in Fig. 6.3.1.

Table 6.2.3 Proposed climatic zoning of Jordan after validation using computer simulations. Cities marked in bold have either heating or cooling load outside the criteria of the actual zone

Zone	Criteria	Stations	Elevation (m)	Heating load (HL) (kWh/m ²)	Cooling load (CL) (kWh/m ²)
1	HL ≥ 18 CL < 13	08 Ramtha	590	20	11
		09 Irbid	616	18	13
		11 Ras-Muneef	1150	38	05
		12 Amman Univ. Jordan	980	30	08
		13 Amman Airport	766	28	07
		15 Naur	910	31	07
		16 Maadaba	785	23	09
		18 Er-Rabah	920	25	08
		19 ElHassen	1200	32	08
		20 Shoubak	1365	44	03
		21 El Qurein	1510	36	06
		23 Mafraq	686	26	10
		25 Wadi Dhuleil	580	23	13
		26 Zarka	555	18	13
		29 Queen Alia Int. Airp.	715	28	07
	31 Jafr	865	20	14	
	32 Ma'an	1069	19	12	
2	10 < HL < 18	10 Taiyiba	373	10	16
	13 ≤ CL ≤ 20	14 Amman Roman Th.	750	16	14
		17 Wadi-Wala	450	11	13
		22 Ruwashed	683	23	17
		24 Safawi	672	22	20
		27 Azraq N	533	18	13
3	HL ≤ 10	01 Baqura	-170	02	24
	CL > 20	02 Shunah	-200	02	23
		03 Wadi Yabis	-200	02	24
		04 Deir Alla	-224	00	26
		05 Ghor-Safi	-350	00	32
		06 Aqaba	51	01	26

From these results and in terms of heating and cooling loads we can conclude that the stations can be classified into three zones (Table 6.2.3): *Zone 1* requires mainly heating, where the heating demand is higher than 18 kWh/m².

Zone 2 where both heating and cooling are equally required in terms of kWh/m².

Zone 3 where the cooling load is the most important.

6.2.3 Conclusions

The climatic zoning of Jordan for winter and summer is based on the Heating Degree Days and Cooling Degree Days. It resulted in defining three climatic zones both for winter and summer. The validation of this climatic zoning through computer simulations with the DEROB-LTH software has confirmed most of these results. Table 6.2.3 is the final result of the climatic zoning. The criteria in terms of heating and cooling loads could be used as reference in future development of an energy code for Jordan.

This climatic zoning should be linked to administrative limits. However, regarding the limited number of cities in Jordan, Table 6.2.3 is sufficiently explicit.

6.3 Thermal requirements for Amman

6.3.1 Method

The method described below can be applied to all the cities of Jordan. In this report only the city of Amman is presented.

In order to identify the optimum U-values for the construction elements for the climatic zone of Amman, we have simulated the thermal behaviour of a high standard apartment which is the most commonly constructed building type with the highest energy use (according to the statistics provided by the Department of Statistics of Jordan (see Section 3.1). The following building element parameters are varied in the simulation:

- External wall insulation
- Roof insulation
- Window size

Other parameters, such as the location of the building in an urban context, the U-values of the windows and shading devices are not investigated in this study but it is recommended to include these aspects in future studies.

To study the thermal impacts of these different parameters, the thermal simulation program DEROB is used. The building elements that are not subject to optimization are given fixed thermal properties.

In order to design for minimum energy consumption for a building in Amman, the heating and cooling loads have to be calculated. The thermal comfort temperature limits for winter and summer are set to 18°C and 26°C respectively. These values are based on the thermal comfort limits which provide the minimum thermal comfort suggested for Amman in this

study, see Section 3.2. The objective of using these is to find the minimum energy consumption.

Building model

The same building model used in the climatic zoning (see Section 6.2) is used for the parametric studies, as shown in Fig. 6.3.1.

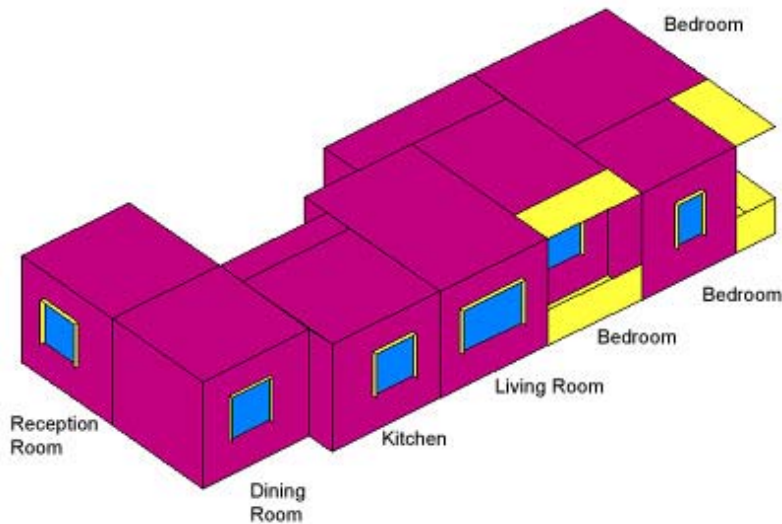

Fig. 6.3.1 The model used for the parametric studies – a typical middle class apartment of 133 m². Southwest perspective of the DEROB-LTH model

The computer model is based on a typical middle class apartment of 133 m², with a reception room, a living room, a kitchen, a bathroom, a toilet and three bedrooms (see the floor plan of a similar apartment in Fig. 4.3.1). The apartment is on the top floor and has three external walls and the roof exposed to the outdoor climate. The building elements and materials are listed in Table 6.3.1.

The internal loads of the different rooms depend on how the apartment is used. The user pattern follows the typical cultural model in Jordan, such as family size, user behaviour (opening and closing windows for ventilation) and domestic energy use. The resulting internal loads and ventilation rates are listed in Tables 6.3.2–6.3.4.

Ventilation rate and internal loads

The ventilation rates are based on the study of a typical Jordanian apartment as described in Section 4.3. Although the measured ventilation rate was 0.34 air changes per hour (ach), the ventilation rate of 0.5 ach was chosen for this study since the measurements were taken in one apartment only.

Table 6.3.1 Construction materials of the apartment model (base case)

<i>Building element</i>	<i>Composition</i>	<i>Thickness (mm)</i>
External walls	Jordan stone	70
	Concrete	180
	Polystyrene insulation	50
	Concrete hollow block	100
	Cement plaster	25
Internal walls	Cement plaster	25
	Concrete hollow blocks	100
	Cement plaster	25
Adiabatic wall	Polystyrene insulation	3000
	Cement plaster	25
	Concrete hollow blocks	100
	Cement plaster	25
Roof	Gravel	100
	Waterproofing asphalt	5
	Concrete	100
	Reinforced concrete	250
	Cement plaster	25
Floor	Earth	500
	Cement plaster	15
	Concrete slab	100
	cement plaster	15
Doors	Wood	40
Windows	Glazing	4

Table 6.3.2 Ventilation rates and internal loads for the period 01 Oct. – 31 Dec. (autumn and beginning of winter)

<i>Hour period</i>	<i>Space 1</i>		<i>Space 2</i>		<i>Space 3</i>		<i>Space 4, 5, 6</i>	
	<i>Vent. rate (ach)</i>	<i>Internal Load (W)</i>	<i>Vent. rate (ach)</i>	<i>Internal Load (W)</i>	<i>Vent. rate (ach)</i>	<i>Internal Load (W)</i>	<i>Vent. rate (ach)</i>	<i>Internal Load (W)</i>
01-06	0.5	10	0.5	10	0.5	10	0.5	150
07-08	1	100	1	300	1	300	1.0	300
09-14	0.5	50	0.5	200	0.5	200	0.5	50
15-21	0.5	200	0.5	300	0.5	500	0.5	300
22-24	0.5	10	0.5	10	0.5	10	0.5	150

Table 6.3.3 Ventilation rates and internal loads for the period 01 Jan. – 31 May (winter and spring)

Hour period	Space 1		Space 2		Space 3		Space 4, 5, 6	
	Vent. rate (ach)	Inter-nal Load (W)	Vent. rate (ach)	Inter-nal Load (W)	Vent. rate (ach)	Inter-nal Load (W)	Vent. rate (ach)	Inter-nal Load (W)
01-08	0.5	10	0.5	10	0.5	10	0.5	150
09-12	1	100	1	300	1.0	300	1	300
13-14	0.5	50	0.5	200	0.5	200	0.5	50
15-18	0.5	200	0.5	300	0.5	500	0.5	300
19-24	0.5	10	0.5	10	0.5	10	0.5	150

Table 6.3.4 Ventilation rates and internal loads for the period 01 June – 30 Sep. (summer)

Hour period	Space 1		Space 2		Space 3		Space 4, 5, 6	
	Vent. rate (ach)	Inter-nal Load (W)	Vent. rate (ach)	Inter-nal Load (W)	Vent. rate (ach)	Inter-nal Load (W)	Vent. rate (ach)	Inter-nal Load (W)
01-08	5	10	5	10	5.0	10	5	150
09-12	10	100	10	300	10	300	10	300
13-14	0.5	50	0.5	200	0.5	200	0.5	50
15-18	0.5	2000	0.5	300	0.5	500	0.5	300
19-24	5	10	5	10	5	10	5	150

The values for the internal loads for winter and summer are based on the findings of a similar study (Grundström et al, 2003).

In summer night ventilation has been practised to cool the building (Table 6.3.4). The times when the apartment should be ventilated as well as the magnitude of the ventilation, have been optimised by computer simulations.

It should be noted that the simulation programme only accepts five time periods.

6.3.2 The party wall

In this study the building is assumed to share a party wall with another building. Little/no heat exchange is expected to occur with the neighbouring apartment, hence the party wall can be considered to be adiabatic, with a U-value of 0.01 W/m²K.

For further studies the number of shared party walls can be varied, such as a detached building or a building with two or three shared party walls.

External walls

External walls are studied according to their thermal performance, principally the thermal insulation. The following U-values ($\text{W}/\text{m}^2\text{K}$) are tested:

- Base case: $U = 0.76$
- Tested cases: $U = 1.5$, $U = 1.25$, $U = 1$, $U = 0.75$, $U = 0.5$

Roof

The roofs were also studied according to their thermal insulation. The following U values ($\text{W}/\text{m}^2\text{K}$) were tested:

- Base case: $U = 1.8$
- Tested cases: $U = 1.5$, $U = 1$, $U = 0.75$, $U = 0.5$

Windows

Windows are single glazed and are optimised according to the following orientations:

- North
- East
- South
- West

For every orientation we test the thermal behaviour of the building as a function of the window to floor ratio (WFR) (that is, the ratio between the window size and floor area expressed in %):

- Base case: 12%
- Tested WFRs: 3%, 7%, 20%, 25%

In this study the main façade is assumed to be facing south.

6.3.3 The process of optimisation

The flowchart in Fig. 6.3.2 schematises the process of optimisation of building elements.

For each element the case of a passive building, showing the thermal behaviour of the building without any heating and cooling, is simulated first followed by a simulation of an actively climatized building.

For the passive case the operative temperature is presented (see definition in Section 3.2, eq. 3.3). The analysis is made for a typical winter day in January and a typical summer day in July based on official climatic data. The day in the climate file being closest to the official average measured day is chosen as a typical day.

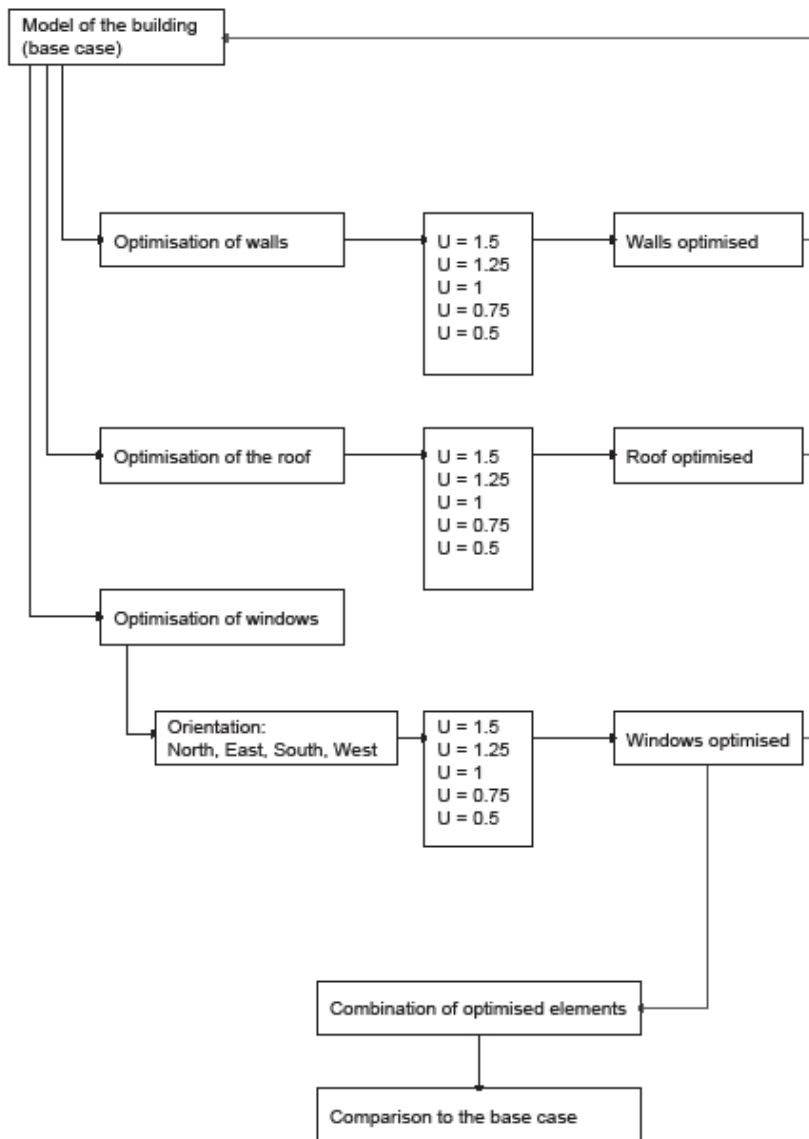

Fig. 6.3.2 Flowchart schematising the process of optimisation of the building elements.

For the active case the apartment is equipped with a heating and cooling system in order to secure a minimum thermal comfort level. The heating level is fixed at 18°C in winter and the cooling level to 26°C in summer. The required energy for heating and cooling is calculated for one year.

Exterior walls optimisation

The thermal properties of five types of walls are studied. The wall compositions are presented in Table 6.3.5 with their respective U-values.

Passive case

Fig. 6.3.3 shows the operative temperature in the living room for the walls with different U-values.

In winter, we note a positive impact on the operative temperature inside the apartment when walls are insulated. The case with the highest level of insulation ($U = 0.5 \text{ W/m}^2\text{K}$) is 1.1°C warmer than the case with the

lowest level of insulation ($U = 1.5 \text{ W/m}^2\text{K}$). The difference between the most insulated case and the base case ($U = 0.67 \text{ W/m}^2\text{K}$) is 0.7°C . During night time when the temperature lays around 14°C the base case wall construction does not meet the minimum thermal comfort level.

Table 6.3.5 Wall types studied. The thickness of the polystyrene insulation is altered to achieve the different U-values

Corresponding Case	Composition		U value ($\text{W/m}^2\text{K}$)
	Material	Thickness (mm)	
Base case	Jordanian stone	70	0.67
	Concrete	180	
	Polystyrene insulation	30	
	Concrete hollow blocks	100	
	Cement plaster	25	
W1	As base case but thinner insulation		1.5
W2	As base case but thinner insulation		1.25
W3	As base case but thinner insulation		1.0
W4	As base case but thinner insulation		0.75
W5	As base case but thicker insulation		0.5

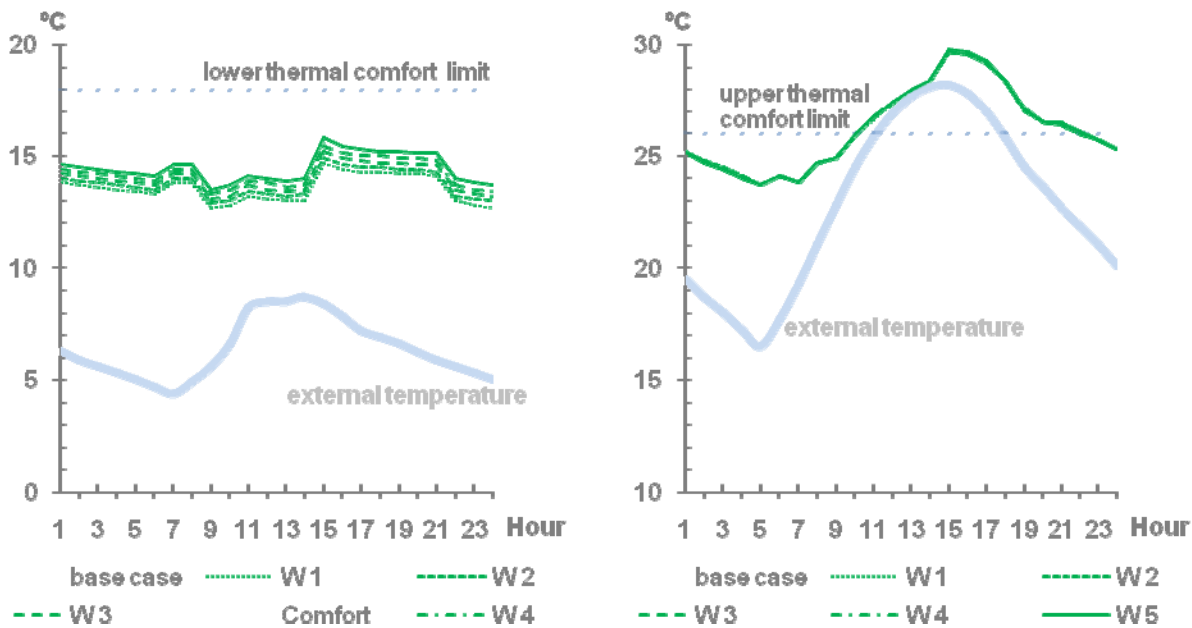

Fig. 6.3.3 Operative temperature in a passive building for walls with different U-values in winter (left) and summer (right).

During summer no significant improvement is noted when the thermal insulation is increased.

For a passive building which is not heated or cooled, wall insulation has a positive effect in winter and no effect in the summer. In spite of increased insulation the building has to be heated in the winter and cooled in summer to achieve thermal comfort.

Active case

Fig. 6.3.4 shows the evolution of the energy required for heating and cooling from the different cases studies.

The use of wall insulation decreases the amount of energy required to heat the apartment in the winter. The higher the insulation (lower U-value), the less energy is required to heat the apartment (lower heating load). However more wall insulation does not always reduce the energy required for cooling in the summer. In fact excessive thermal insulation diminishes the possibility of natural cooling of the building, because the building acts like a “thermos” where the building interior is kept warm.

The optimum thermal insulation is between case W0 and W5. A U-value of walls between 0.5 and 0.67 W/m^2K is recommended.

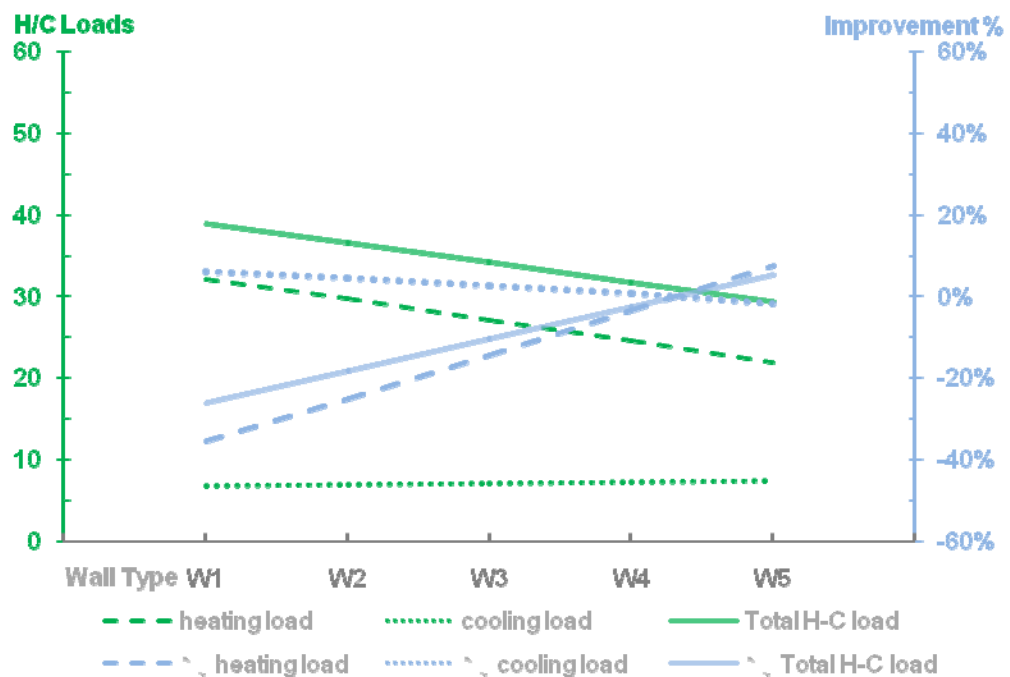

Fig. 6.3.4 Energy required annually (kWh/m^2) for heating and cooling to reach the thermal comfort zone for walls with different U-values. The graph also shows the change in energy use in % compared to the base case.

Roof optimisation

Five types of roof constructions with different U-values are tested as shown in Table 6.3.6.

Passive case

Following the same method as for the walls, the thermal behaviour of the model is studied for different levels of thermal insulation of the roof. Fig. 6.3.5 shows the results for the winter and summer cases.

Table 6.3.6 Composition of the different roofs studied. The thickness of the polystyrene insulation is altered to achieve the different U-values

Corresponding case	Composition Building materials	thickness(mm)	U values (W/m ² K)
Base case	Gravel-jee	100	1.39
	Asphalt coating	5	
	Concrete	100	
	Reinforced concrete	250	
	Cement plaster	25	
R1	As base case but thinner insulation		1.5
R2	As base case but thicker insulation		1.27
R3	As base case but thicker insulation		1.0
R4	As base case but thicker insulation		0.75
R5	As base case but thicker insulation		0.5

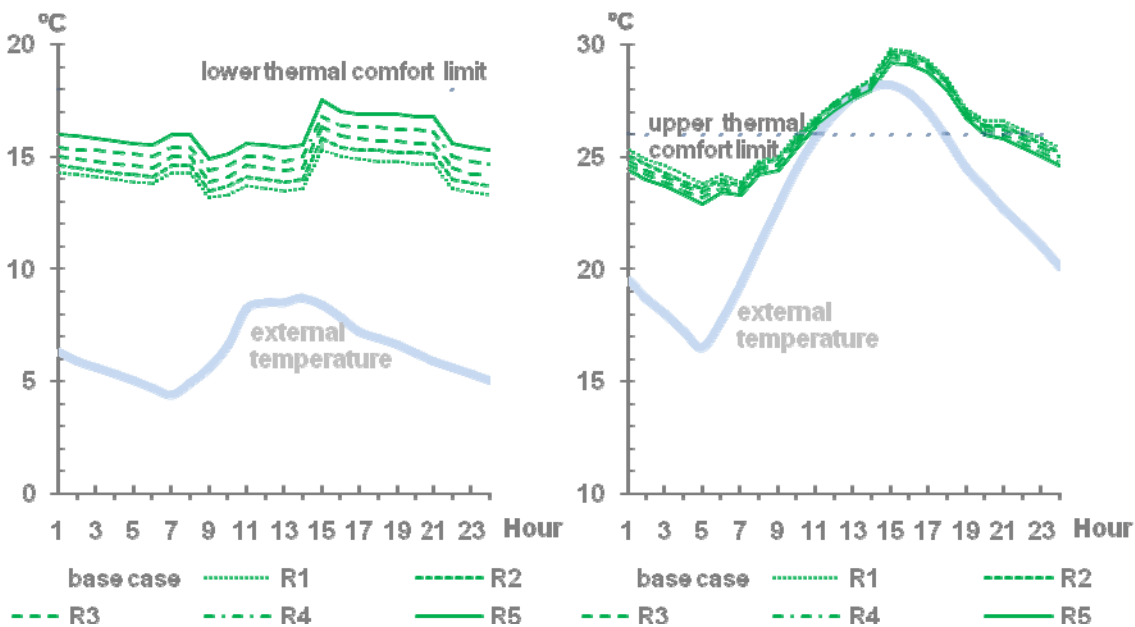

Fig. 6.3.5 Operative temperature in a passive building for roofs with different U-values in winter (left) and summer (right).

When the roof is insulated, the indoor climate is noticeably improved in both winter and summer. In the winter the average temperature is increased by 1.7°C. In summer the average indoor temperature is also improved with a decrease of 0.6°C.

For a passive building, increased roof insulation has a positive effect both in winter and summer. However, similarly to the case of the walls, there is a need for an active source of energy for heating and cooling the apartment to reach the thermal comfort zone.

Active case

Fig. 6.3.6 shows the required heating and cooling loads for the different cases studied.

Insulating the roof results in a significant decrease of the heating load of the apartment; from 7% reduction for a U-value of 1.0 W/m²K to 53% reduction for a U-value of 0.5 W/m²K.

There is also a 27% reduction of the cooling load when the roof is insulated. The energy required to cool the building is half the amount required to heat the building.

The adequate U-value will depend on the target for energy saving and on the payback period of the investment in roof insulation. A U-value of the roof between 0.5 and 0.7 W/m²K is recommended. This will lead to a total saving of 34-45% compared with the base case.

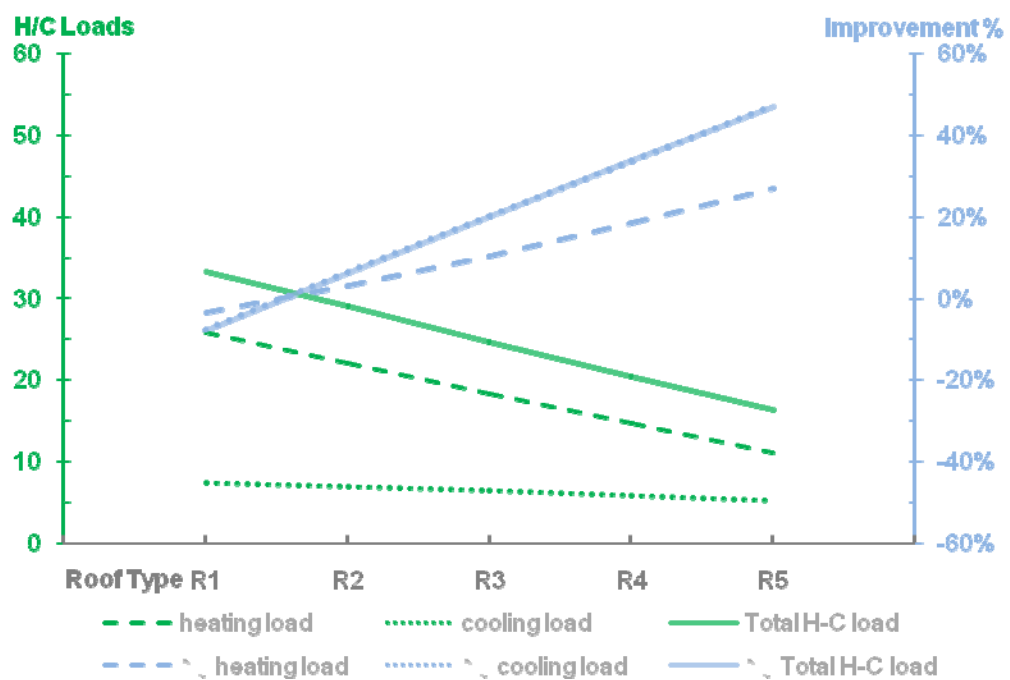

Fig. 6.3.6 Energy required annually (kWh/m²) for heating and cooling to reach the thermal comfort zone for walls with different U-values. The graph also shows the change in energy use in % compared to the base case.

Optimisation of windows

A south facing window with five different opening sizes is tested. The percentages of window compared to floor area are: 3%, 7%, 12%, 20% and 25%, where the base case corresponds to a Window to Floor Ratio (WFR) of 12%.

We note here that WFR corresponds to the glazed area of the window; the frame is not included.

Passive case

Fig. 6.3.7 shows that the WFR has a positive correlation with the operative temperature in both the winter and the summer. In the winter,

a larger WFR improves the operative temperature, with an average increase of between 0.4 to 1.0°C.

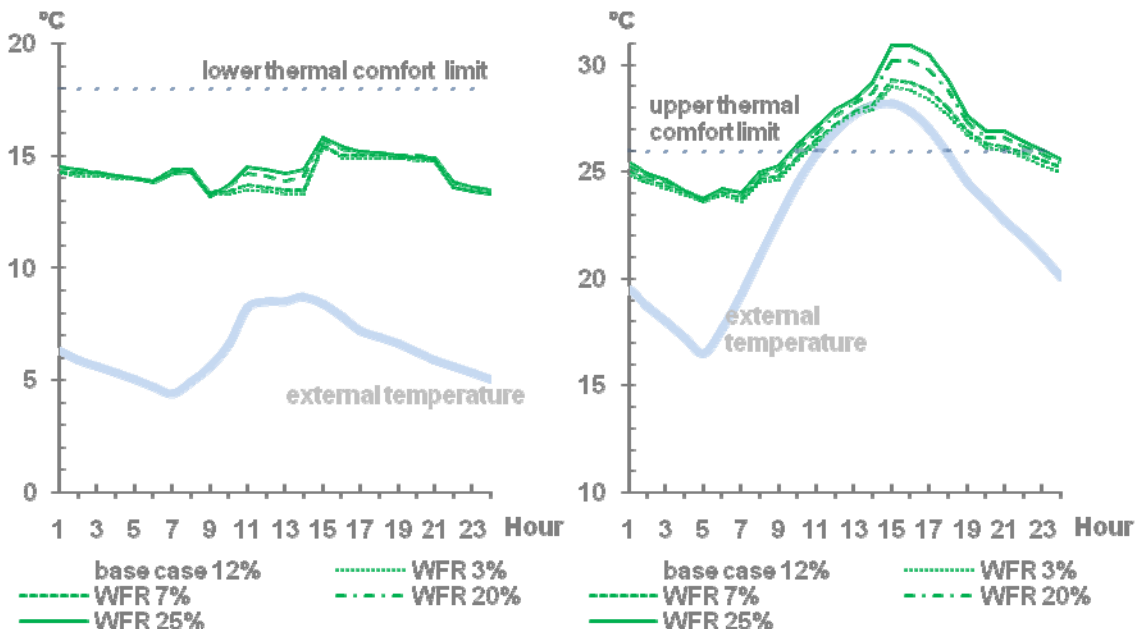

Fig. 6.3.7 Operative temperature variation on an average winter and summer day.

However in the summer a large WFR creates a thermally uncomfortable environment in the daytime, with average operative temperatures of 26.4°C and 26.7°C for WFR = 20% and WFR = 25% respectively.

Hence a WFR of around 15% is adequate annually for a passively heated apartment in Amman.

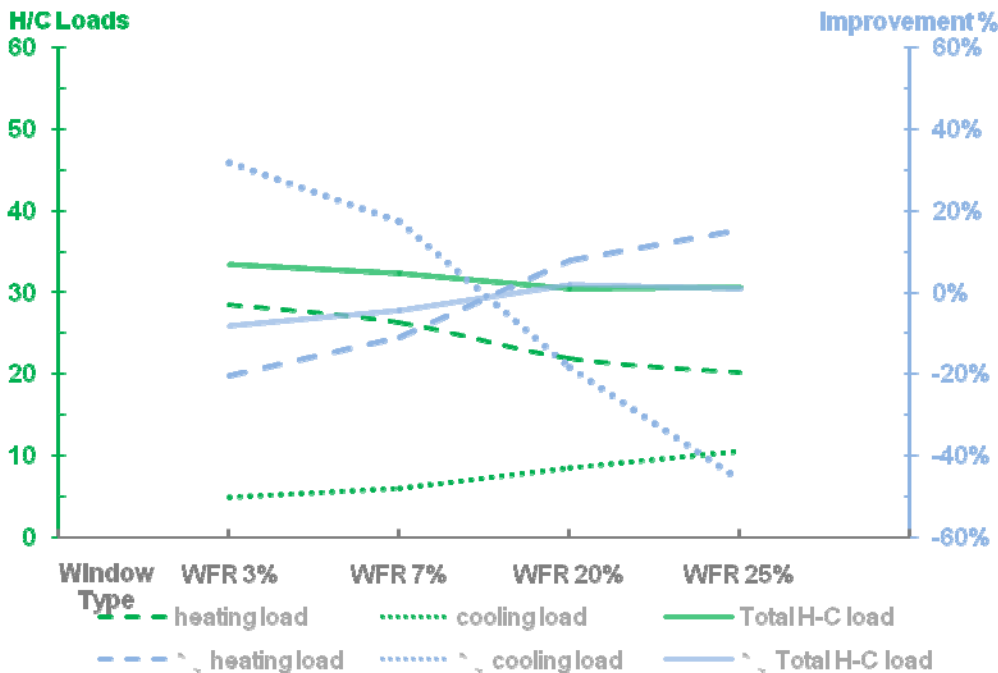

Fig. 6.3.8 Energy required annually (kWh/m²) for heating and cooling to reach the thermal comfort zone for windows with different wall-to-floor-ratios (WFR). The graph also shows the change in energy use in % compared to the base case.

Active case

Fig. 6.3.8 shows the required heating and cooling loads for the different cases studied. In the winter, we note a decrease in the heating load when the WFR is above the base case level of 12%.

In the summer, however, a larger WFR increases the operative temperature. Unless shutters are used overheating will become a serious problem that the cooling system has to overcome and more energy is required to cool the apartment.

The optimum WFR for a south oriented building would be between 15% and 20%.

This process of optimization should be applied also for the other orientations of the building.

Combination of optimized elements

This section compares the thermal behaviour of the apartment combining all the optimised building elements with the base case. The optimum case has the following characteristics:

- External wall insulation: $U=0.5 \text{ W/m}^2\text{K}$
- Roof insulation: $U=0.5 \text{ W/m}^2\text{K}$
- Window orientation: South
- WFR: 12%.

Passive case

Fig. 6.3.9 presents the operative temperature of the base case and the optimum case in an apartment without an active heating and cooling system in the winter and summer.

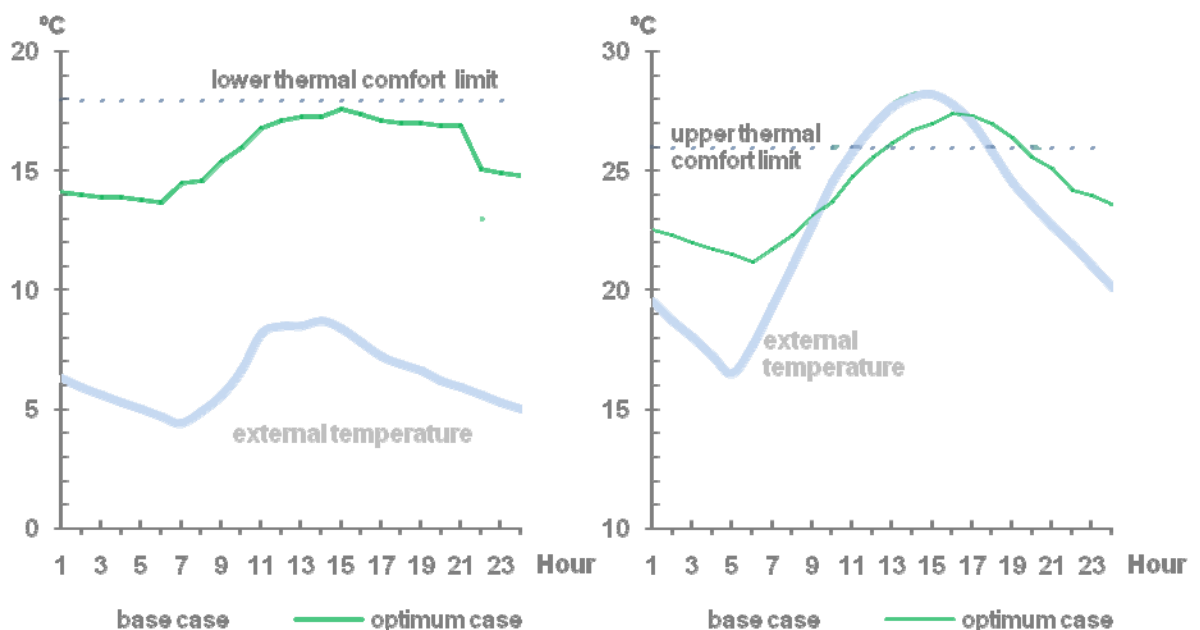

Fig. 6.3.9 Operative temperature for the base case and the optimum case in winter (left) and summer (right).

The indoor climate in winter is considerably improved when using the optimised building elements, with an increase in temperature of 2.3°C in the daytime and 1.3°C at night. Even without a heating or cooling system, the optimised model almost reaches the lower limit of thermal comfort in the daytime. However it falls below comfort level at night.

The optimised model improves the thermal comfort of the apartment in the summer compared to the base case, by a decrease of around 1.6°C in the daytime and around 0.6°C at night.

Active case

Fig. 6.3.10 shows the energy savings by the optimised model compared to the base case in an apartment with an active heating and cooling system.

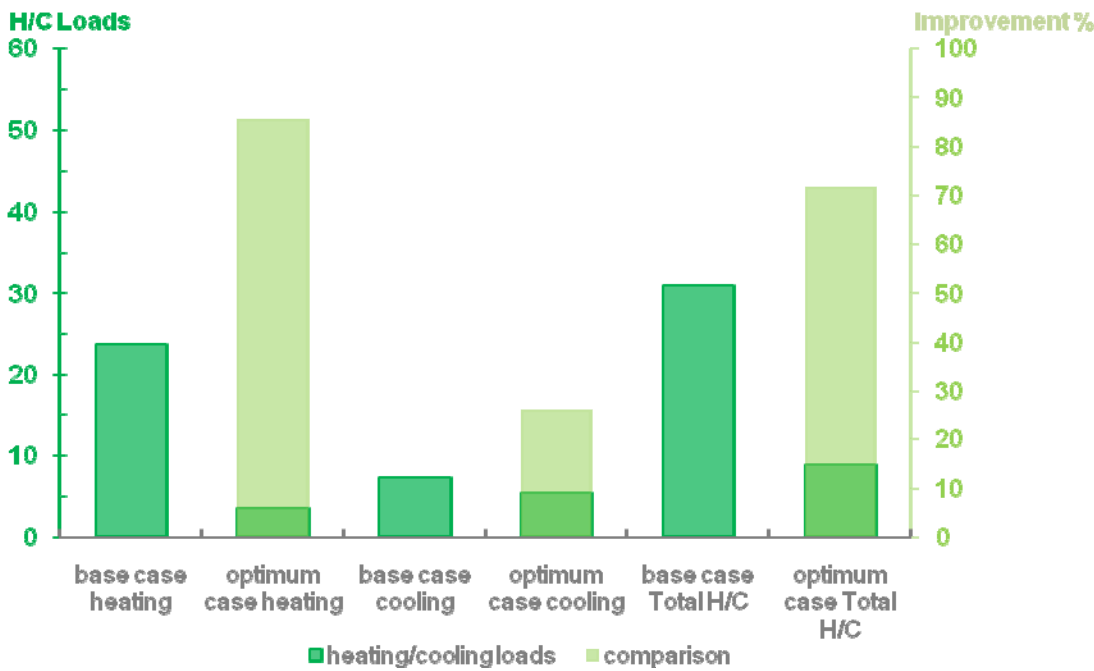

Fig. 6.3.10 Energy required annually (kWh/m²) for heating and cooling to reach the thermal comfort zone for the base case and the optimum case.

By using the optimised building elements recommended in this study, a saving of 86% can be made on the heating load and 26% on the cooling load. Hence a total of 72% can be saved on the heating and cooling loads. This is significant in terms of economic and environmental savings, as less fuel is consumed and less CO₂ is emitted. Hence this is a justified investment to improve insulations for walls and the roof and the payback period is likely to be short. However optimising the WFR may be difficult in an existing apartment without altering the structure of the building.

Remarks

There is no specific data on energy needed for heating and cooling of this type of apartment, or other types of buildings (see Section 3.1). Hence the results on heating and cooling are obtained from the computer simulations described in this chapter.

6.4 Climate-conscious urban design for Amman

6.4.1 Urban design regulations in Amman

Urban design in Amman is governed by “An Amended Regulation of the Buildings and Zoning in Amman City for the year 2005” (Amman Municipality 2005) which is an amendment to Regulation no. 67 from 1979. The land-use zones of Amman contain residential areas, commercial areas, industrial areas and office areas. The regulations contain rules on maximum number of storeys, maximum building heights, road widths, building percentage (plot coverage)⁵, floor area ratio (FAR)⁶, setbacks, etc.

Residential buildings

The areas designated for residential purposes in urban areas are divided into the sectors A, B, C, D and popular housing, see Table 6.4.1. The minimum plot sizes for different housing area sectors vary between 150 m² (popular housing area) to 1000 m² (sector A). The provisions in regard to building percentage (plot coverage), number of floors, building height, setbacks and the maximum FAR for each sector are shown in Table 6.4.1 and in Fig. 6.4.1.

Table 6.4.1 Zoning provisions of housing sectors A, B, C and D

Housing Sector	Max. building percentage	Max. no. of floors	Max. FAR	Max. building height (m)	Setback (m)		
					Front	Back	Sides
A	39%	4	1.6	15	5	7	4
B	45%	4	1.8	15	4	6	4
C	51%	4	2.0	15	4	4	3
D	55%	4	2.2	15	3	2.5	2.5
Popular	–	4	–	–	2	2	–

Source: Amman Municipality, 2005

Building projections are only allowed for aesthetic purposes or as solar shading. Balconies are not allowed to exceed the permitted building line.

Reflective materials that might disturb the neighbours or might be public safety hazards are forbidden. Not more than 20% of the exterior elevations is allowed to be painted with colours other the colour of stone or white.

⁵ Ratio of the building area (footprint area) to the area of the piece of land on which the building is located

⁶ Floor area ratio (FAR), sometimes called plot ratio, is calculated as the total gross floor area of a building divided by the total area of the plot.

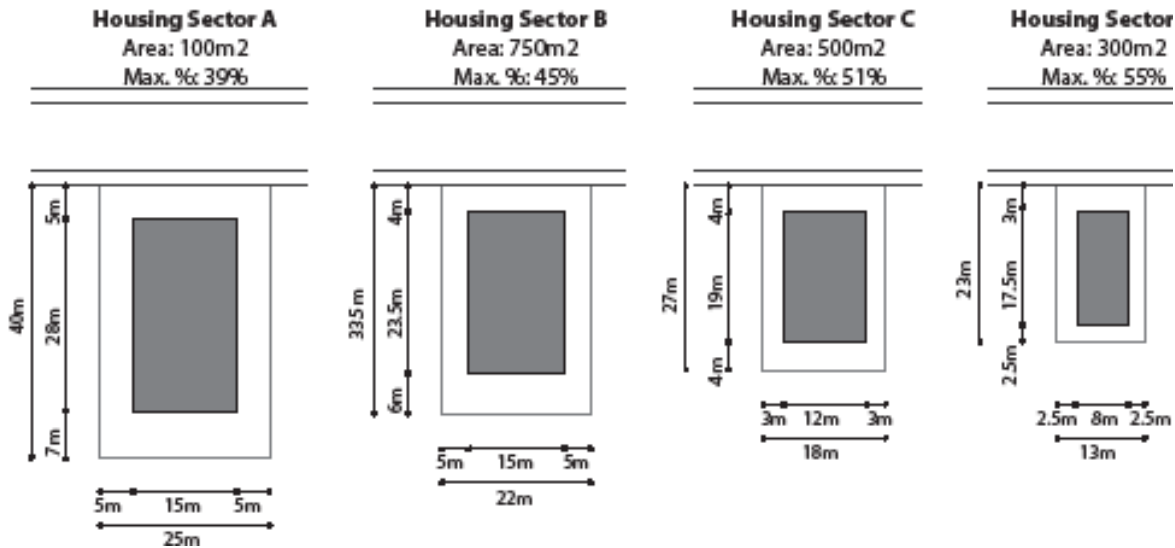

Fig. 6.4.1 Regulations of plot size, building percentage and setbacks for housing sectors A, B, C and D.

Commercial buildings

The commercial areas are intended for commercial, residential, public and worship purposes. The zones of commercial buildings are divided into central and ordinary commercial sectors. There are also local commercial sectors within the housing sectors.

Buildings in the commercial sectors will be subjected to the provisions in Table 6.4.2. This is further illustrated in Fig. 6.4.2.

Table 6.4.2 Zoning provisions of commercial sectors

Commercial Sector	Max. plot coverage (%)	Plot size (m ²)	Max. FAR	Max. building height (m)	Build- ing depth (m)	Setback (m)		
						Front	Back	Sides
central	85	<200	6	72		—	*	*
		>200	10			—		
ordinary	70	<600	6		<18	—	4	—
		>600	8.5	**	>18	—	4	4

Source: Amman Municipality, 2005

* The setback could be either backward or sideways provided that any distance will be at least 2.5 m from the plot border. The building may have a courtyard of minimum 15% of the plot size.

** The maximum building height should be equal to the street width along with the front setback, if any, however maximum 72 m.

The lands in the local commercial area will be subjected to the provisions applicable to the housing area wherein the piece of land is located.

The limits for objects projecting out from the building periphery are as follows:

- Balconies overlooking streets and plazas should not project from the building periphery line by more than 1.8 m when the street width is 18

m or more, and not more than 1.4 m when the street width is less than 16 m. Balconies are not allowed in streets less than 10 m wide.

- The distance between the end of the projection and adjacent plot boundary should not be less than 1.5 m in all cases and the vertical distance below the projection to the side walk should not be less than 3 m.
- Concrete, fabric and metal protection shadings should not have a depth of more than 2.5 m.
- Architectural projections should not be more than 0.75 m deep.

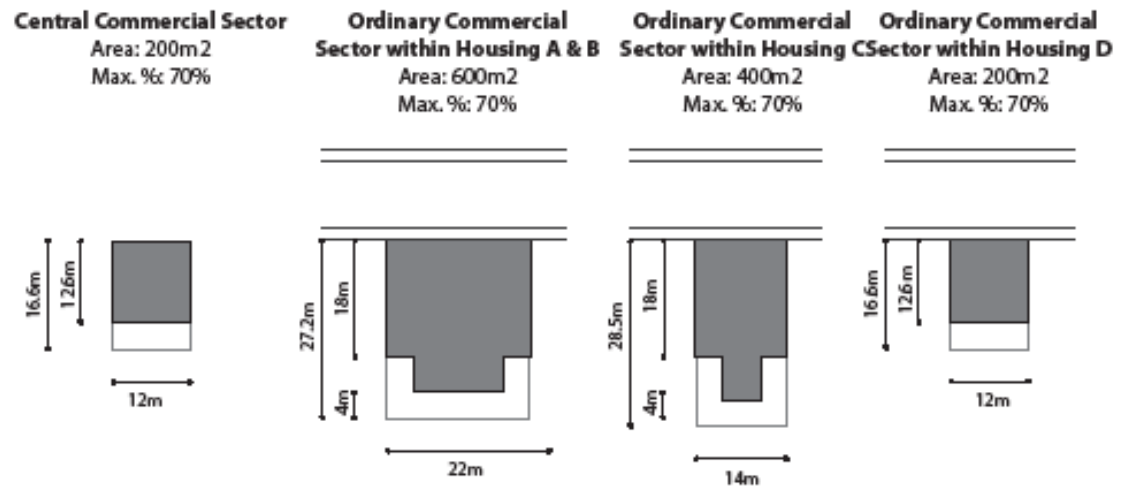

Fig. 6.4.2 Regulations of plot size, building percentage and setbacks for the Central and Ordinary Commercial Sectors

6.4.2 Microclimate simulations

The simulation tool – ENVI-met

The software ENVI-met, version 3.0 (Bruse 2008, Ali-Toudert and Mayer 2006), designed to analyse the relationship between urban design and microclimate, was chosen for the simulations. This model combines the calculation of fluid dynamics parameters such as wind flow and turbulence with the thermodynamic processes taking place on the ground surface, on the walls, roofs and in the vegetation.

Parametric study

Modelling the base case

Based on the regulations regarding building heights, street widths and setbacks, a model of a typical urban area is developed. The model is based on a Type C residential zoning as this is the most common type.

The base case is a simplified small urban area with typical geometric characteristics, material properties, façade colours and ground elements. The model area consists of two rows of plots with seven plots on each side

of a street (Fig. 6.4.3). The buildings are 12 m high (4 floors). The road width is 12 m – slightly narrower than the stipulated minimum width of 14 m. The setbacks are in accordance with the regulations (front and rear setbacks = 4 m, side setbacks = 3 m). This results in the street height-to-width ratio (H/W) of 0.6. The base model has no vegetation.

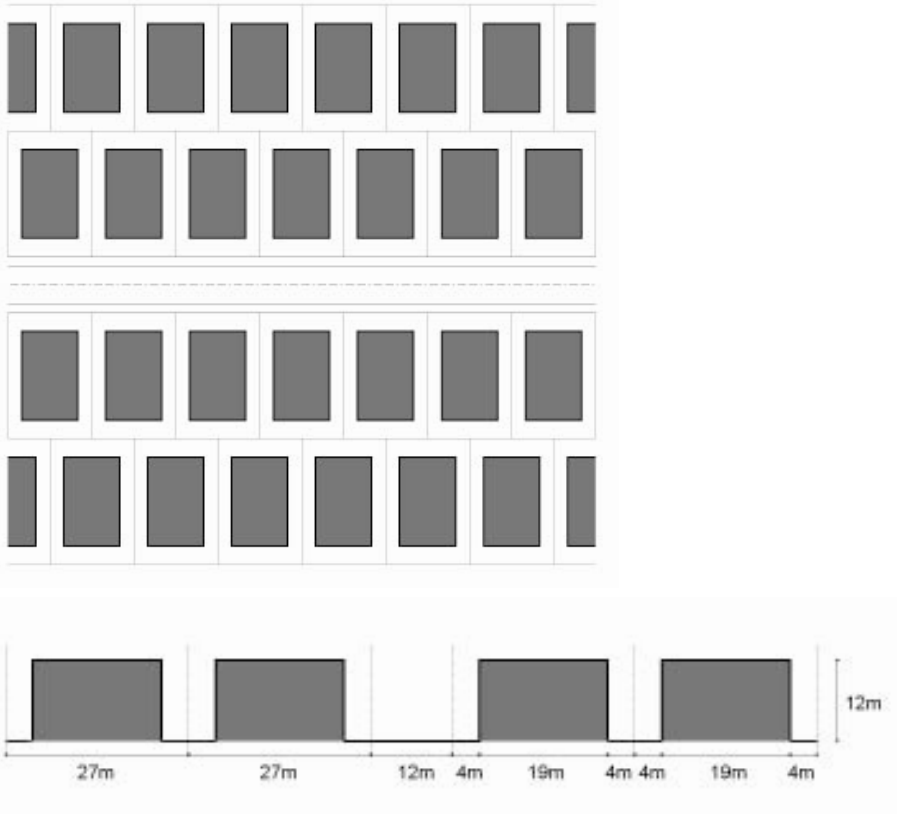

Fig. 6.4.3 (a) Plan and (b) section of the model area of the base case. The H/W ratio of the street is 0.6.

Table 6.4.3 Input data for the summer and winter base case simulations

	Summer	Winter
Building height, H (m)	12	12
Distance between buildings, W (m)	20	20
H/W ratio	0.6	0.6
Wind speed (at 10 m height) (m/s)	2.0	1.5
Indoor temperature (°C)	28	20
U-value, walls (W/m ² °C)	0.7	0.7
U-value, roof (W/m ² °C)	1.4	1.4
Reflectivity, façades	0.3	0.3
Reflectivity, roofs	0.3	0.3
Reflectivity, street	0.2	0.2
Clothing value (for PMV calculation)	0.5	1.5

Amman has a very hot summer and a fairly cold winter, whereas both spring and autumn are quite comfortable.

Two base cases are created, one for the summer and one for the winter. The summer is represented by 15 July and the winter by 15 January. The input data of the base cases are shown in Table 6.4.3. The wind speed in urban areas is considerably lower than in rural areas and the wind speed used in the simulations have been assumed to be 50% of the figures given by the meteorological office.

Parametric study

The simulations are performed as a parametric study in which different characteristics of urban canyons are subjected to adjustment. Only one parameter is changed at a time in order to determine the relative influence of each. The effects of the following design parameters on microclimate and thermal comfort are studied:

- H/W ratio (varying the street width and front setback)
- Street orientation
- Reflectivities of the ground (dark and less dark colours)
- Arcades for shading pedestrians
- Vegetation as shading

The design parameters of the simulation cases are described in Table 6.4.4. Street orientation for all simulations is east-west. However, the north-south orientation is also studied in one case. Reflectivity values represent realistic ranges of stone façades (medium dark) and dark to medium-dark streets.

The effect of arcades is simulated using a street with arcades on both sides of the street (Fig. 6.4.4). The effect of shading by trees is simulated by placing a continuous row of trees along both pavements of the base case. The trees are planted on the pavement but their crowns cover both the pavement and the front yard of the plots, see Fig. 6.4.5.

Table 6.4.4 The design parameters for the simulation cases

	Base case	Changed parameters		
H/W ratio	0.6	0.75	1.0	1.5
Ground Reflectivity	0.2	0.4		
Orientation	E-W	N-S		
Arcades	No	Yes		
Shading trees	No	Yes		

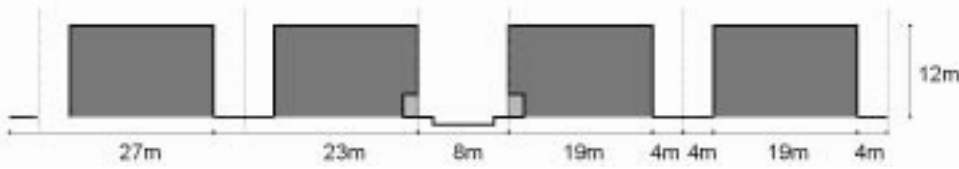

Fig. 6.4.4 Section of the simulation case with arcades on both sides of the street, no front setbacks and the street width reduced from 12 to 8 m. This case has a H/W ratio of 1.5.

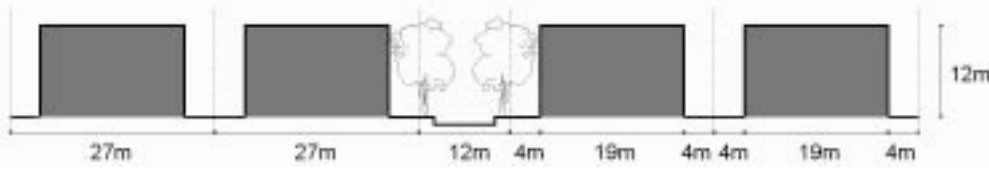

Fig. 6.4.5 Section of the simulation case with shading trees.

Finally, all of the changes found to improve the microclimate and thermal comfort at street level are combined to form a “best case” scenario. A solution is sought that could improve thermal conditions for both summer and winter. However, since the heat stress in the summer is considered to be more problematic than the cold discomfort in winter, more emphasis is placed to solve the summer case.

Simulation of the microclimate and outdoor thermal comfort

The detailed output of the ENVI-met model, which contains climate parameters of each grid cell within the model area, makes it possible to visualize the spatial variation of the microclimate and the thermal comfort.

Outdoor thermal comfort is estimated using the Predicted Mean Vote (PMV) index. Although this index is designed for indoor thermal comfort and may have limited relevance outdoors (see e.g. Nikolopoulou et al, 2001) it can be used in a parametric study since it allows a comparison of different cases. The thermal sensation scale of PMV is shown in Section 3.2, Table 3.2.4.

6.4.3 Results

Air temperature

The simulated air temperatures are shown in Fig. 6.4.6 (left, summer) and Fig. 6.4.6 (right, winter). In general, the air temperature does not vary much between the cases. However the increase of the H/W ratio leads to a decrease in maximum air temperature (at around 14:00), but this decrease is small ($< 1^{\circ}\text{C}$ in summer and $< 0.5^{\circ}\text{C}$ in winter). In the summer, the biggest decrease is achieved by using trees and higher reflectivity of the pavements and roads.

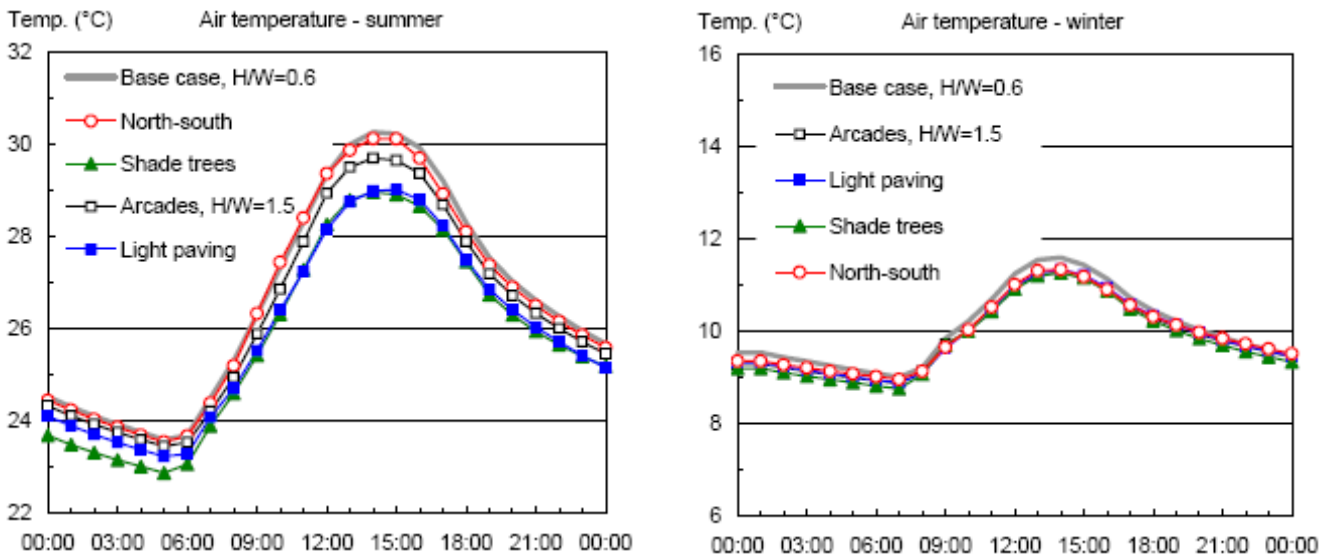

Fig. 6.4.6 Simulation results of air temperature for (left) the summer day (15 July) and (right) the winter day (15 January).

Street surface temperature

The simulated street surface temperatures for the middle of the street are shown in Fig. 6.4.7 (left, summer) and Fig. 6.4.7 (right, winter). In the summer, the surface temperature decreases when the street is in the shade between 11:00 and 13:00 for the case with arcades and no front setback. In the summer, the case with lighter street colour is considerably cooler than the base case (up to 7°C cooler). In the winter, this case is also cooler but only by up to 1.5°C. The most significant decrease in temperature is from the use of trees as shading in summer (up to 18°C cooler). In the winter however, when the deciduous trees are assumed to have no leaves, it is not cooler than the other cases. In the winter, the case with north-south orientation has a peak temperature at around noon when the solar radiation enters the canyon.

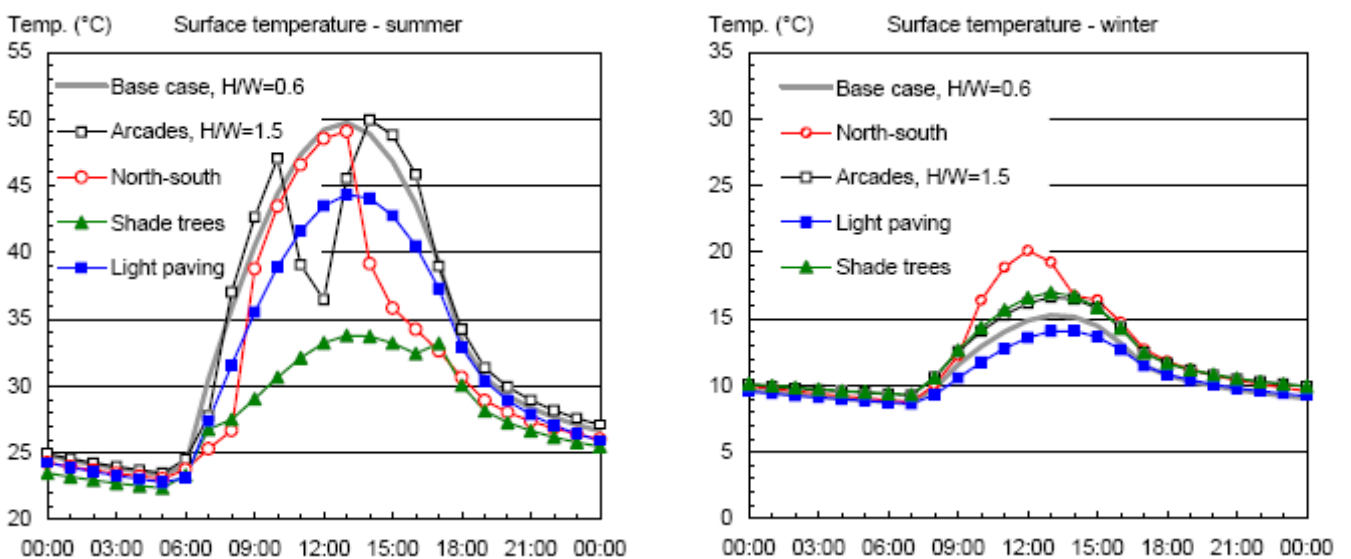

Fig. 6.4.7 Simulation results of street surface temperature for (left) the summer day (15 July) and (right) the winter day (15 January).

Outdoor thermal comfort

The outdoor thermal comfort expressed as the PMV index is shown for some of the cases in both summer (Fig. 6.4.8) and winter (Fig. 6.4.9). The results are shown for midday when the solar radiation is at its peak.

In the summer, the use of arcades creates shading which significantly improves the thermal comfort for pedestrians on the street (Fig. 6.4.8 b). The use of trees has a similar effect (Fig. 6.4.8 c).

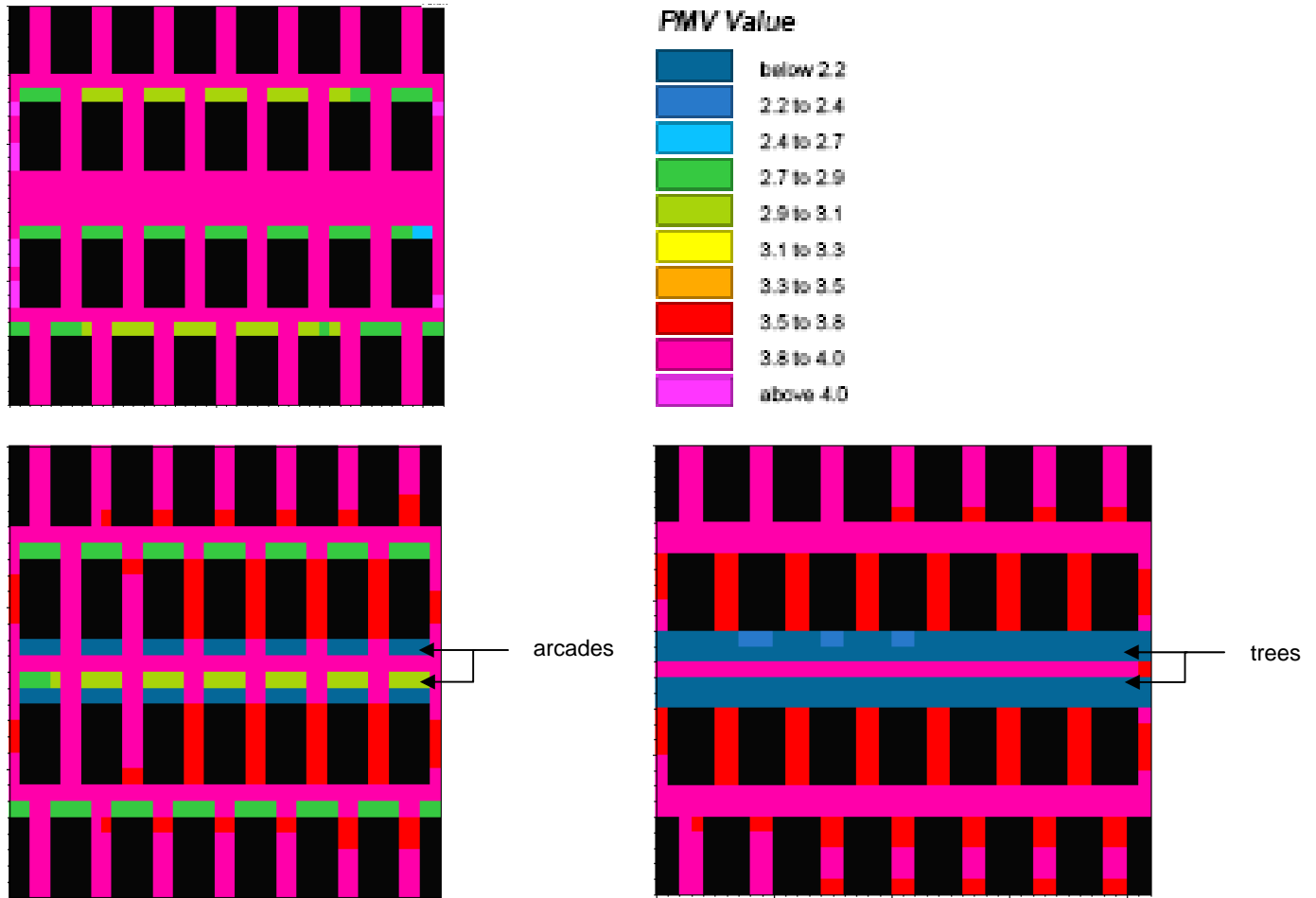

Fig. 6.4.8 Thermal comfort expressed as PMV at 12:00 in summer for the Base case (top left), arcades, no front setback and narrower street (bottom left), and shade trees (bottom right).

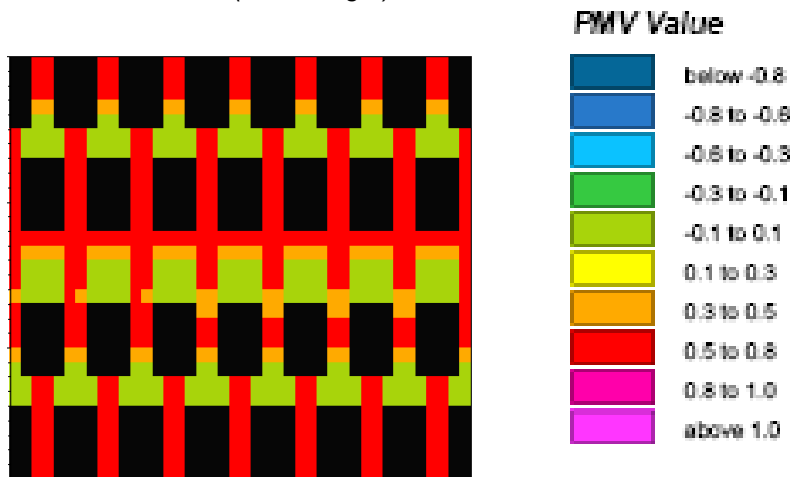

Fig. 6.4.9 Thermal comfort expressed as PMV at 12:00 in winter for the Base case.

In the winter, the difference between the simulated cases proved to be insignificant. From the base case result shown in Fig. 6.4.9, it can be seen that most of the street is in the shade at 12:00, but the variation in PMV within the model area is small.

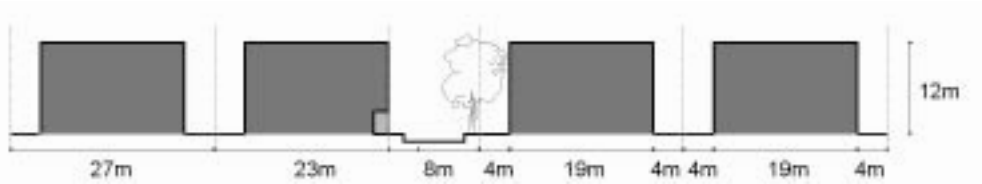

Fig. 6.4.10 Section of the “Best case” scenario having an 8 m wide E-W oriented street with arcades along its southern side and shade trees along its northern side.

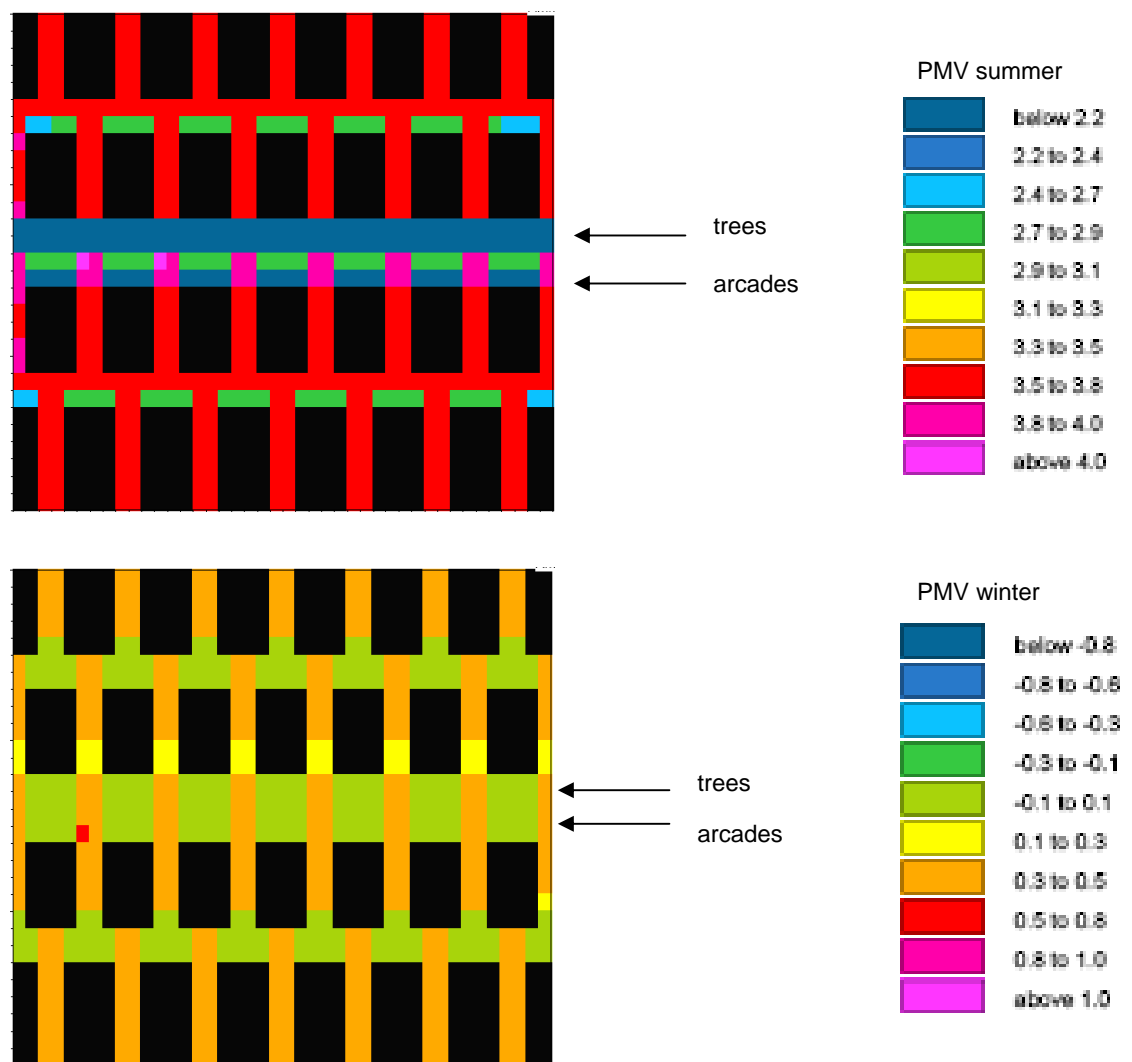

Fig. 6.4.11 Results of the “best case” in summer (top) and winter (bottom). The E-W oriented street has arcades along its southern side and shade trees along its northern side.

Optimization

Finally, the changes leading to the improved thermal comfort – i.e. the use of arcades, trees and higher reflectivity paving – are combined into a “best case” scenario.

The “best case” scenario is an 8 m wide E-W oriented street with arcades along its southern side and trees along its northern side, Fig. 6.4.10. As shown in Fig. 6.4.11, this solution greatly improves thermal conditions in the summer without significantly decreasing thermal comfort in winter.

6.4.4 Discussion and recommendations

Effect of urban design on the microclimate

The variation of the H/W ratio has a minor effect on the air temperature. However, the effect of H/W ratio on the surface temperature is more significant: a narrower street with more shading results in a lower street temperature. This is positive for the thermal comfort as the thermal radiation from the street decreases (lower PMV).

The simulated effect of orientation on air temperature is found to be limited. However, the effect on surface temperatures and PMV can be significant. In general, north-south oriented streets are less exposed to solar radiation in summer.

Shading by arcades and trees on the street is very efficient in lowering PMV in the summer. The trees do not lower PMV in winter since the trees are assumed to be deciduous and thus without leaves.

An increase in the reflectivity of the street from 0.2 to 0.4 proves to reduce the ground surface temperature and the PMV. This is an advantage in the summer, but a disadvantage in the winter. However, the positive effect in the summer is bigger than the negative effect in winter. It should be noted that it is not possible to have very light surfaces due to the risk of glare. It may also be difficult to maintain light colours due to dust in a hot dry climate.

The role of urban codes

The Building Regulations and Zoning in Amman have a major impact on urban design since they include strict regulations on building heights, street widths, setbacks, etc. However in general, the regulations, whose origin date back to the times when Jordan was part of the British Mandate of Palestine, are largely inappropriate from a climate point of view. Instead of promoting shade, which is crucial in a warm climate with intense solar radiation, these codes stipulate large distances between buildings.

In residential areas, a low maximum building heights, fairly wide roads and front setbacks of 3–5 m lead to a dispersed urban form. Consequently H/W ratios are low and typically vary between about 0.6 and 0.75. Moreover, projections from buildings which could act as shading devices are restricted or prohibited.

Undoubtedly the urban codes of Amman need to be better adapted to the local climate conditions, or at least be more flexible than they are today.

Recommendations for Amman

The existing urban form in Amman is suitable for the winter climate. However, since the summer season is longer and it is more difficult to adapt behaviour and clothing to warm conditions, it is recommended that the majority of streets be designed for good summer comfort. This would require a far more compact urban design of future urban areas.

Higher H/W ratios could be achieved either by allowing narrower streets – which could be suitable for one-way roads or pedestrian streets, or by allowing the buildings to be higher – which is more suitable for streets intended for motor traffic.

For Amman, it is recommended that buildings have no front setbacks, in order to increase the possibilities of shade for pedestrians. Moreover, overhead shading in the form of projected upper floors, arcades, shading trees or other devices to improve thermal comfort for pedestrians should be promoted. The use of arcades is especially suitable in mixed use areas, with commercial activities on the ground floor and residential and office use on the upper floors.

Deciduous trees are suitable since they provide shade in summer and allow solar access in winter. Such trees could be used along sidewalks and in public spaces.

In order to provide comfort in winter, some streets – preferably oriented east-west – should have a low H/W (0.7 or less). By using arcades, covered walkways and/or trees, such a street may provide comfort for pedestrians also in summer.

Open public spaces should be sufficiently large to allow solar access in winter. They should however be provided with overhead shading to improve comfort in summer.

These suggestions of a more compact urban design also have the advantage of leading to higher building (FAR) and population densities and thus a more efficient land-use.

These recommendations are likely to be valid also for other cities in Jordan with similar climate as Amman. However, in other climate zones, for example the Jordan Valley and the region of Aqaba, a separate study similar to this one, should be conducted.

7 Conclusions and recommendations

7.1 Testing as support for energy efficiency of buildings

7.1.1 g-value and thermal resistance of solar shutters

The solar simulator at Lund University is used to test the g-value of four Jordanian roller-shutters. The brightness of the shutter surface is the most important factor; the white shutters have a considerably lower g-value than the dark ones. The heat resistance for the four shutters is also tested and the resulting U-values for the roller blinds together with double or single panes are calculated. The most notable result is that the shutters made by aluminium and cavities filled with insulation have a lower resistance value than those made of PVC with no insulation in the cavities. The reason is that the aluminium lamellae act as thermal bridges.

7.1.2 Ventilation rates in a residential apartment

Most apartments in Jordan are naturally ventilated. The principle of ventilation is usually opening the window combined with a ventilation shaft, which functions as a passive stack in the middle of the building. The facade construction is often masonry, which means that most air leakage paths are likely to be related to leaky windows.

Ventilation heat losses can constitute an important part of the overall energy losses of a building. Information on ventilation rates are needed when calculating the energy use of a building. For an apartment with natural ventilation it is difficult to calculate the ventilation rate, which is affected by the air tightness of the building envelope, use of windows for airing, ventilation openings and shafts/ducts, wind speed and the natural driving forces (temperature difference between the inside and the outside). There is very little knowledge on the actual ventilation rate and air tightness of Jordanian apartments. Therefore the ventilation rate was measured in one typical apartment. The average measured ventilation rate during the winter period was 0.31 ach \pm 13%, which is fairly low. This is due to the fairly small average temperature difference between inside and outside the low wind speed (2.7 m/s), and that the windows were closed most of the time (except from the morning airing). The average measured ventilation rate during the summer period was 2.38 ach \pm 13%,

which is rather high. This is due to the fact that most of the windows were half opened during day and night. The driving forces for the ventilation were rather small.

In order to improve the understanding of the energy use of Jordan residential buildings, better knowledge on ventilation rates are needed. Measurements of one apartment are not sufficient. Two approaches are possible:

- Additional measurements of ventilation rates in real apartments
- Measurements of the air tightness of apartments, i.e. the building envelope.

The first method requires the use of passive tracer gas techniques. The second method is simpler with the use of a blower door to test several apartments (<http://www.energyconservatory.com>). During the measurements the air leakages paths are preferably located using smoke sticks and infrared thermography. These kinds of measurements typically require a couple of hours per apartment. The results can be used as inputs in energy simulations using e.g. DEROB-LTH. This way the influence of ventilation rates on energy use can be estimated.

7.1.3 Advice for future laboratory testing

Some ideas for new test facilities at the Royal Scientific Society (RSS) are suggested, and alternative uses of existing ones are discussed.

The existing twin test rooms at the RSS have the disadvantage that an accurate evaluation is difficult, as many sources of heat flow with different time lag are involved. Testing the heat demand is relatively easy as the amount of electric heating maintaining the room at constant temperature can be measured. On the other hand, testing the cooling demand require the installation of cooling devices together with measurement and control equipment for the cooling.

Measuring the direct solar transmission through window components using an integrating sphere is suggested. Optical measurements can be obtained relatively quickly as the thermal mass is not involved. In Jordan where a clear sky is accessible on most days, the integrating sphere is suggested to use the sun as light source which has the benefit of parallel light and the spectrum of the sun.

Twin boxes to measure the g-value on window/sunshade systems are suggested. Boxes using passive cooling to the air are devised, thus complicated and expensive cooling and control units are avoided. The heat from the sun through the window system is absorbed on a solar collector, transferred to water and then cooled by a heat exchanger to the air. The boxes are intended to be small and light to keep thermal mass down. In this way they also can be easily tilted to test at different incidence angles.

A simple method for calorimetric measurements of g-value for totally opaque shadings is devised. The tested shading device is mounted on a frame that has a back cover that serves as a heat flow meter. The back cover has a foam core and an integrated thermopile consisting of copper-

constantan wires. Fans are agitating the air on the back. A pyranometer measures the irradiation from the sun.

Hot-box equipment for the measurement of U-values is available at the RSS. It is now used for testing of walls. In addition, a specially made partition wall with an opening for testing of windows is suggested. The U-value of the central glass parts of a window is well known or easy to calculate, whereas the frame and a possible box for roller blinds can have large thermal bridges which are hard to estimate without testing.

Jordan has very favourable conditions for using solar thermal systems. A system with the storage tank placed outdoors and above the collector using natural convection is simple and cost effective. The circulation starts spontaneously when the temperature of the water in the collector is higher than in the tank and stops when the collector has a lower temperature. The performance of such systems is usually tested by drawing off the collected hot water after the day-time period of heating. This is done in order not to interfere with the stratification in the tank during the solar heating phase. A system with natural circulation and vacuum tubes is recently developed in China. It is interesting to compare such a system with a flat plate collector system, preferably simultaneously.

A relatively large system of flat plate solar collectors is installed at the RSS. It is suggested that this system will be monitored, either by utilizing the hot water or by dumping the heat into the air with a heat exchanger.

Monitoring and testing the performance of photo-voltaic systems could be a way to gain experience and knowledge. Therefore the testing of both a stand-alone system and a grid connected system is suggested.

7.2 Software development as support for energy efficiency of buildings

To support architects and heating, ventilating and air-conditioning (HVAC) consultants in the building design process, the design tools DEROB-LTH and ParaSol have been adapted to Jordanian needs.

The ventilation model in DEROB-LTH has been completely replaced by a more advanced one. Now it is possible to study both mechanically and naturally ventilated buildings, schedule leakages through opened windows and between internal volumes e.g. through a door or a staircase. The model is sensitive to specified leakage flows and leakage areas in external walls and between internal walls. To make full use of the model, wind data should be part of the climatic data for the studied site. Detailed results about the simulated ventilation are provided.

To control the HVAC model, a more advanced scheduling function has been developed. Set points, heating power, internal loads, air flows, window openings and openings between internal walls can now be scheduled with a higher resolution.

The same post-processor for daylight calculations used in the ParaSol program has been added. It supports studies of daylight illumination in a room. Only one room can be studied at a time and the room geometry is limited to be a right-angled parallelepiped.

A Jordanian type of solar shutter has been modelled and included in the ParaSol program. It is possible to specify a ventilated air gap and the width between the window and the shutter. The material thickness of the shutter can be given as well. A ventilated air gap can not be combined with a ventilated window (double façade).

The U-value of the external wall can be varied. To be able to use external walls in a Jordanian context, the range of possible U-values for the external wall has been extended to 1.5 W/m²K.

The ParaSol program can be downloaded from www.parasol.se and is free of charge. A licence for the DEROB-LTH program can be ordered from Energy and Building Design at Lund University (<http://www.ebd.lth.se/>).

7.3 Thermal requirements for building elements

The thermal requirements investigated for Amman in this project are limited to apartment buildings. This is by far the most common construction type in the last decade and constitutes the largest consumer of energy in terms of heating and cooling. Therefore this is a highly significant construction type to be made more energy efficient.

The results from the optimization process carried out for the climate of Amman have found the principal requirements to be:

- A U-value for roof to be between 0.5 to 0.7 W/m²K
- A U-value for walls to be between 0.5 and 0.7 W/m²K
- A Window to Floor Ratio (WFR) for a south oriented building to be between 12% and 20%

These requirements would allow a total saving in energy for cooling and heating of up to 70%, compared to an actual apartment.

Further reductions in energy use are possible and future studies in Jordan should investigate other aspects not presented in this report including shading, different orientations of the building and the positioning of the building in an urban context. Other climatic zones of Jordan should also be studied.

A way to optimize thermal performance could be to establish a total envelope U-value for buildings in different climatic zones, as an envelope U-value offers more flexibility than a U-value for each building element.

We stress that the work carried out towards a new energy code for buildings is a first step which needs to be further developed and updated continuously, for example every two to three years, in order to actualize it according to new development and for it to become stricter gradually.

The climate of Jordan shows great potential of passive heating using solar energy. With an adequate design it should be possible to achieve so-

called zero energy buildings, that is buildings which require virtually no energy for heating and cooling. However, there are several obstacles achieving this including:

- **Socio-culturally:** Apartments and houses are generally oversized, where some spaces are rarely used, such as large reception rooms. This is a waste of resources in two ways; more building materials, energy and human resources are needed to construct these spaces and further energy is required to maintain these spaces at a thermally comfortable level.
- **Technically:** It is common to use thermal insulation in Jordan, however it is often badly applied resulting in thermal bridges and heat is often lost through gaps in the thermal insulation layer. There is a need for more adequate training for the construction workers applying thermal insulation and developing better equipment and procedures.

7.4 Climate-conscious urban design

The study on thermal conditions in urban areas was concentrated on the capital of Amman, which with a population of about 2.2 million is by far the largest city in Jordan. Amman is currently experiencing a very high construction activity and the city is growing rapidly. In such a situation it is important that climate aspects are considered, otherwise there is a risk that the urban development will result in thermally uncomfortable and unhealthy environments. This will lower the quality of living and moving around the city.

The climate of Amman is characterized by long, hot and dry summers and fairly cold winters. The challenge with such a climate is to design appropriately for both seasons. In this study, the microclimate in Amman in both summer and winter was analyzed using the advanced microclimate software ENVI-met.

Large areas of Amman, especially in the residential zones, have a dispersed urban form with low floor area ratios. This type of urban design is fairly comfortable during the winter season, because it allows some solar radiation to reach the street level. The current design is, however not well suited for the long, hot and dry summer season because it provides little shade for pedestrians.

The dispersed urban form of Amman is a result of the urban codes. Limitations on maximum building height, minimum road widths and front setbacks have led to low height-to-width ratios of street canyons. Consequently the floor area ratios are low.

In order to be able to provide a climate-conscious urban design that takes the hot summer conditions into account, more shade at street level is necessary. This can be provided through a more compact urban design with higher height-to-width ratios than those currently applied and through different forms of overhead shading, e.g. arcades and other types of covered walkways. However, the cold season also has to be considered and some wider streets and open public spaces should be designed for

solar access. In Section 6.4 some recommendations and examples of appropriate street design are given.

The urban codes of Amman need to be changed and be made more flexible in order to provide a climate-conscious urban design. Shading of pedestrians at street level and in public places should preferably be promoted by the urban codes.

Moreover it is important for planners and urban designers to be knowledgeable about urban climate. The development of climate-conscious urban planning and design guidelines is important.

In this study it was shown that a more compact urban design than that currently practised in Amman would lead to a far better outdoor thermal comfort in summer. Such a design would lead to higher floor area ratios, higher population densities and, consequently, a more efficient use of land.

8 References

- Al-Asir, H. and Johansson, E. (2008)
Urban Microclimate – simulations for the summer and winter in Amman Project report. Royal Scientific Society, Jordan and Housing Development & Management, Lund University, Sweden.
- Ali-Toudert, F., and Mayer, H. (2006)
“Numerical study on the effects of aspect ratio and orientation of an urban street canyon on outdoor thermal comfort in hot and dry climate”. *Building and Environment* 41: 94-108
- Amman Municipality (2005)
Building Regulation and Zoning in Amman City, Ammended regulation of the buildings and zoning in Amman, Amman: Amman Municipality.
- Arnfield, A.J. (2003)
Two decades of urban climate research: a review of turbulence, exchanges of energy and water, and the urban heat island. *International Journal of Climatology*, vol. 23, pp. 1-26.
- ASHRAE (1997)
Handbook of Fundamentals, American Society of Heating, Refrigerating and Air-conditioning Engineers (ASHRAE). Atlanta, Georgia, United States of America
- ASHRAE (2004)
Thermal Environmental Conditions for Human Occupancy, ASHRAE Standard 55-2004, American Society of Heating, Refrigerating and Air-Conditioning Engineers, Atlanta
- BEE (2006)
Energy Conservation Building Code 2006. New Delhi: Bureau of Energy Efficiency (BEE).
- Blomsterberg, Å. (2008)
Ventilation rates in an apartment in Amman – Results from measurements. *Energy and Building Design*, Department of Architecture and the built environment, Lund Unisversity.
- Bouden, C. and Ghrab, N. (2005)
“An adaptive thermal comfort model for the Tunisian context: a field study results”, *Energy and Buildings*, vol. 37, pp. 952-963
- Bruse, M. (2008)
ENVI-met website. <http://www.envi-met.com>
- Bülow-Hübe, H. (2001)
Energy-Efficient Window Systems. (Report TABK-01/1022, chapter 6 and Article V). Lund: Department of Architecture and Built Environment, Lund University, Sweden.
- Busch (1992)
A tale of two populations: thermal comfort in air-conditioned and naturally ventilated offices in Thailand, *Energy and Buildings*, vol. 18, pp. 235-249

de Dear and Brager (2002)

“Thermal comfort in naturally ventilated buildings: revisions to ASHRAE Standard 55”, *Energy and Buildings*, vol. 34, pp. 549-561

DOS (2008)

The Hashemite Kingdom of Jordan Department of Statistics (DOS), http://www.dos.gov.jo/dos_home_e/main/index.htm

Emmanuel (2005)

An urban approach to climate-sensitive design: strategies for the tropics. Spon Press, London

Fanger, P.O. and Toftum, J. (2002)

“Extension of the PMV model to non-air-conditioned buildings in warm climates”, *Energy and Buildings*, vol. 34, pp. 533-536

Givoni (1998)

Climate Considerations in Building and Urban Design. New York: Van Nostrand Reinhold

Grundström, K., Johansson, E., Mraissi, M., Ouahrani, D. (2003)

Climat & Urbanisme – La relation entre le confort thermique et la forme du cadre bâti. Report 8. Lund: Housing Development & Management

Hellström, B. (2007)

DEROB-LTH, Ventilation model, Theoretical background. Lund: Department of Architecture and Built Environment, Lund University, Sweden.

ISO (1994)

ISO 7730: Moderate thermal environments – Determination of the PMV and PPD indices and specification of the conditions for thermal comfort. 2nd edition, International Organisation for Standardisation.

Johansson, E. (2006)

Urban Design and Outdoor Thermal Comfort in Warm Climates – Studies in Fez and Colombo, PhD Thesis. Lund, Sweden: Housing Development & Management (HDM), Lund University.

Johansson (2008)

Energy Building Codes – a literature review of building envelope insulation. Project report. Royal Scientific Society, Jordan and Housing Development & Management, Lund University, Sweden.

Källblad, K. (1998a)

DEROB-LTH, Shading of Diffuse Radiation, Theoretical background, Department of Building Science, Lund University, Sweden.

Källblad, K. (1998b)

DEROB-LTH, Thermal Model of Windows, Theoretical background, Department of Building Science, Lund University, Sweden.

Källblad, K. (1998c)

DEROB-LTH, The Comfort Program, Theoretical background, Department of Building Science, Lund University, Sweden.

- Kvist, H (2008)
DEROB-LTH Manual. Energy and Building Design, Lund University, Sweden.
- Markus, T.A. and Morris, E.N. (1980)
Buildings Climate and Energy. London: Pitman publishing.
- McIntyre, D.A. (1980)
Indoor Climate. Applied Science Publishers, London
- MPWH (1990)
Thermal Insulation Code. Amman: Ministry of Public Works and Housing (MPWH) (In Arabic)
- MPWH (2008)
Thermal Insulation Code. Amman: Ministry of Public Works and Housing (MPWH) (In Arabic)
- Nicol, F. and Roaf, S. (1996)
“Pioneering new indoor temperature standards: the Pakistan project”, *Energy and Buildings*, vol. 23, pp.169-174
- Nicol, F., and Humphreys, M.A. (2002)
“Adaptive thermal comfort and sustainable thermal standards for buildings”, *Energy and Buildings*, vol. 34, pp. 563-572
- Nikolopoulou, M., Baker, N. and Steemers, K. (2001)
“Thermal comfort in outdoor urban spaces: understanding the human parameter”, *Solar Energy*, vol. 70, pp. 227–235
- Nikolopoulou, M. and Steemers, K. (2003)
“Thermal comfort and psychological adaptation as a guide for designing urban spaces”, *Energy and Buildings*, vol. 35, pp. 95–101.
- Oke (1987)
Boundary Layer Climates. 2nd edition, London, New York: Routledge
- Oke (2004)
Initial guidance to obtain representative meteorological observations at urban sites, World Meteorological Organization (WMO), Geneva.
- Oseland, N.A. and Humphreys, M.A. (1994)
Trends in thermal comfort research, BR 266, Building Research Establishment, Watford.
- Spagnolo, J.C. and de Dear, R.J. (2003)
“A field study of thermal comfort in outdoor and semi-outdoor environments in subtropical Sydney Australia”. *Building and Environment*, vol. 38, pp. 721-738.
- Stymne, H. et.al. (2006)
“Passive Tracer Gas Measurement of the Long Term Variation of Ventilation in Three Swedish Dwellings”. *International Journal of Ventilation*, Volume 5, Number 3.